

# OPERATOR'S MANUAL

# PX20P-XXX-XXX-AXXX

INCLUDING: OPERATION, INSTALLATION AND MAINTENANCE

RELEASED: 12-16-02

REVISED: 8-30-19

(REV: U)

## 2" DIAPHRAGM PUMP 1:1 RATIO (NON-METALLIC)



**READ THIS MANUAL CAREFULLY BEFORE INSTALLING,  
OPERATING OR SERVICING THIS EQUIPMENT.**

It is the responsibility of the employer to place this information in the hands of the operator. Keep for future reference.

### SERVICE KITS

Refer to Model Description Chart to match the pump material options.

**637373-XXX** for fluid section repair **with** seats (see page 5).

**637373-XX** for fluid section repair **without** seats (see page 5).

**NOTE:** This kit also contains several air motor seals which will need to be replaced.

**637369** for air section repair (see page 7).

**637374-X** major air valve assembly (see page 8).

### PUMP DATA

**Models** ..... see Model Description Chart for "-XXX".

**Pump Type** ..... Non-Metallic Air Operated Double Diaphragm

**Material** ..... see Model Description Chart.

**Weight** ..... PX20E-FES-XXX ..... 85.3 lbs (38.7 kgs)

PX20P-FKS-XXX ..... 110.9 lbs (50.3 kgs)

PX20E-FNS-XXX ..... 110.9 lbs (50.3 kgs)

PX20P-FPS-XXX ..... 85.3 lbs (38.7 kgs)

**Maximum Air Inlet Pressure** ..... 120 psig (8.3 bar)

**Maximum Material Inlet Pressure** ... 10 psig (0.69 bar)

**Maximum Outlet Pressure** ..... 120 psig (8.3 bar)

**Maximum Flow Rate** (flooded inlet) ..... 184 gpm (696 lpm)

**Displacement / Cycle @ 100 psig** ..... 1.4 gal. (5.3 lit.)

**Maximum Particle Size** ..... 1/4" dia. (6.4 mm)

**Maximum Temperature Limits (diaphragm / ball / seal material)**

E.P.R. / EPDM ..... -60° to 280° F (-51° to 138° C)

Hytre<sup>®</sup> ..... -20° to 180° F (-29° to 82° C)

Nitrile ..... 10° to 180° F (-12° to 82° C)

Polypropylene ..... 32° to 175° F (0° to 79° C)

PVDF (Kynar<sup>®</sup>) ..... 10° to 200° F (-12° to 93° C)

Santoprene<sup>®</sup> ..... -40° to 225° F (-40° to 107° C)

PTFE ..... 40° to 225° F (4° to 107° C)

Viton<sup>®</sup> ..... -40° to 350° F (-40° to 177° C)

**Dimensional Data** ..... see page 9

**Mounting Dimension** ..... 8.18" x 14.16" (207.8 mm x 359.7 mm)

**Noise Level @ 70 psig, 60 cpm** ..... 85.0 dB(A)<sup>①</sup>

<sup>①</sup> The pump sound pressure levels published here have been updated to an Equivalent Continuous Sound Level (LA<sub>eq</sub>) to meet the intent of ANSI S1.13-1971, CAGI-PNEUROPS 55.1 using four microphone locations.

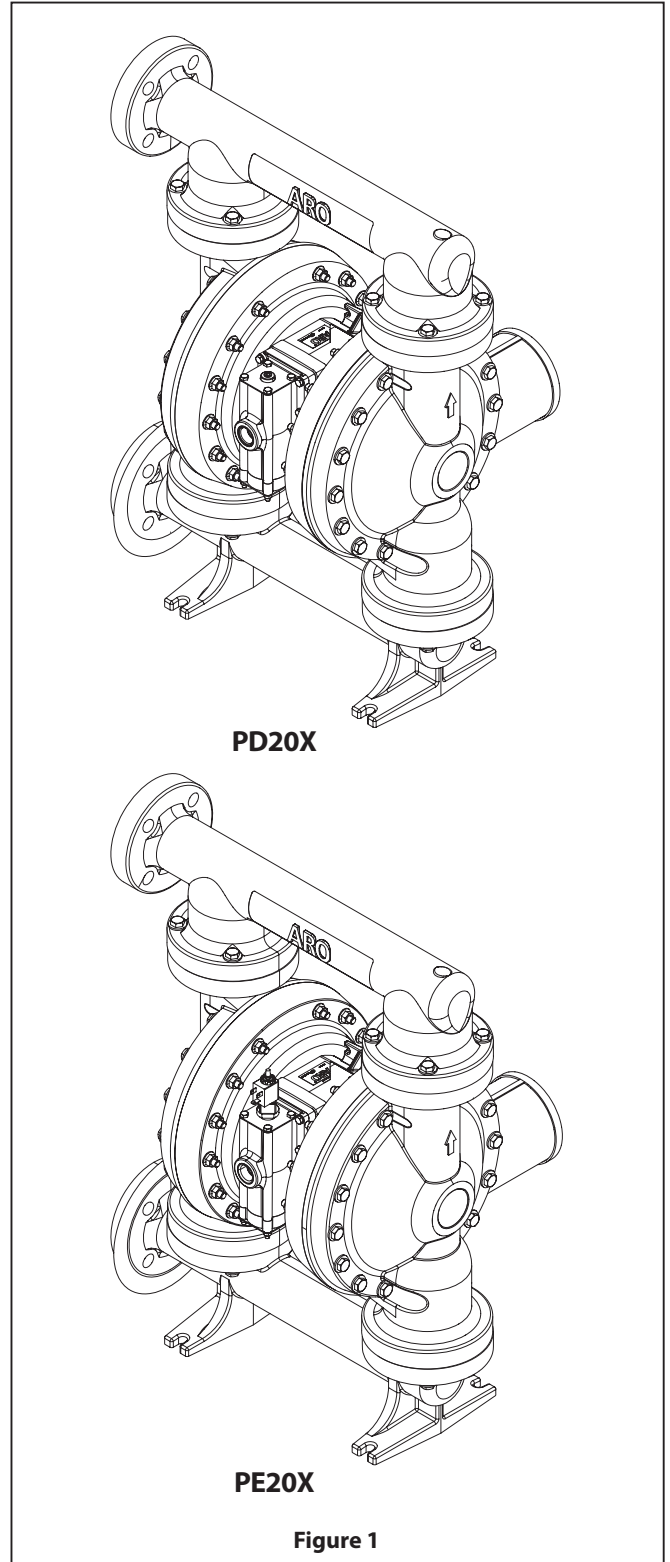

Figure 1

INGERSOLL RAND COMPANY LTD  
209 NORTH MAIN STREET – BRYAN, OHIO 43506

① (800) 495-0276 • FAX (800) 892-6276

© 2019

CCN 20083440

arozone.com

**ARO**  Ingersoll Rand<sup>®</sup>

# MODEL DESCRIPTION CHART

**Model Code Explanation**

<b>Example:</b>	PX20	X	-	X	X	X	-	X	X	X	-	A	X	X	X
<b>Model Series</b>															
PD20- Standard Pump															
PE20- Electronic Interface															
<b>Center Body Material</b>															
E - Conductive Polypropylene															
P - Polypropylene / Vinyl Ester															
<b>Fluid Connection</b>															
F - 2" ANSI / DIN Flange															
<b>Fluid Caps And Manifold Material</b>															
E - Conductive Polypropylene															
K - PVDF															
N - Conductive Polyvinylidene Fluoride (PVDF)															
P - Polypropylene															
<b>Hardware Material</b>															
S - Stainless Steel															
<b>Seat Material</b>															
K - PVDF															
P - Polypropylene															
<b>Ball Material</b>															
A - Santoprene®															
C - Hytrel®															
G - Nitrile															
S - 316 Stainless Steel															
T - PTFE															
V - Viton®															
<b>Diaphragm Material</b>															
A - Santoprene®															
C - Hytrel®															
G - Nitrile															
L - Long Life PTFE / Santoprene®															
M - Medical Grade Santoprene®															
T - PTFE / Santoprene®															
V - Viton®															
<b>Revision</b>															
A - Revision															
<b>Specialty Code 1 (Blank if no Specialty Code)</b>															
A - Solenoid 120 VAC, 110 VAC AND 60 VDC															
B - Solenoid 12 VDC, 24 VAC AND 22 VAC															
C - Solenoid 240 VAC, 220 VAC AND 120 VDC															
D - Solenoid 24 VDC, 48 VAC AND 44 VAC															
E - Solenoid 12 VDC NEC / CEC															
F - Solenoid 24 VDC NEC / CEC															
G - Solenoid 12 VDC ATEX / IECEX															
H - Solenoid 24 VDC ATEX / IECEX															
J - Solenoid 120 VAC NEC / CEC															
K - Solenoid 220VAC ATEX / IECEX															
N - Solenoid with no Coil															
P - Ported Motor (No Major Valve)															
0 - Standard Valve Block (No Solenoid)															
S - Cycle Sensing on Major Valve															
<b>Specialty Code 2 (Blank if no Specialty Code)</b>															
E - End of Stroke feedback + Leak Detection															
F - End of Stroke feedback															
G - End of Stroke ATEX / IECEX / NEC / CEC															
H - End of Stroke + Leak Detection ATEX / IECEX / NEC / CEC															
L - Leak Detection															
M - Leak Detection ATEX / IECEX / NEC / CEC															
R - End of Stroke NEC															
T - End of Stroke NEC / Leak Detection NEC															
0 - No Option															
<b>Special Testing</b>															
For Special Testing options, please contact your nearest <b>Ingersoll Rand</b> Customer Service Representative or Distributor.															
<b>NOTICE: All possible options are shown in the chart, however, certain combinations may not be recommended. Consult a representative or the factory if you have questions concerning availability.</b>															

## OPERATING AND SAFETY PRECAUTIONS

READ, UNDERSTAND, AND FOLLOW THIS INFORMATION TO AVOID INJURY AND PROPERTY DAMAGE.



**⚠ WARNING** EXCESSIVE AIR PRESSURE. Can cause personal injury, pump damage or property damage.

- Do not exceed the maximum inlet air pressure as stated on the pump model plate.
- Be sure material hoses and other components are able to withstand fluid pressures developed by this pump. Check all hoses for damage or wear. Be certain dispensing device is clean and in proper working condition.

**⚠ WARNING** STATIC SPARK. Can cause explosion resulting in severe injury or death. Ground pump and pumping system.

- Sparks can ignite flammable material and vapors.
- The pumping system and object being sprayed must be grounded when it is pumping, flushing, recirculating or spraying flammable materials such as paints, solvents, lacquers, etc. or used in a location where surrounding atmosphere is conducive to spontaneous combustion. Ground the dispensing valve or device, containers, hoses and any object to which material is being pumped.
- Secure pump, connections and all contact points to avoid vibration and generation of contact or static spark.
- Consult local building codes and electrical codes for specific grounding requirements.
- After grounding, periodically verify continuity of electrical path to ground. Test with an ohmmeter from each component (e.g., hoses, pump, clamps, container, spray gun, etc.) to ground to ensure continuity. Ohmmeter should show 0.1 ohms or less.
- Submerge the outlet hose end, dispensing valve or device in the material being dispensed if possible. (Avoid free streaming of material being dispensed.)
- Use hoses incorporating a static wire.
- Use proper ventilation.
- Keep inflammables away from heat, open flames and sparks.
- Keep containers closed when not in use.

**⚠ WARNING** Pump exhaust may contain contaminants. Can cause severe injury. Pipe exhaust away from work area and personnel.

- In the event of a diaphragm rupture, material can be forced out of the air exhaust muffler.
- Pipe the exhaust to a safe remote location when pumping hazardous or inflammable materials.
- Use a grounded 1" minimum ID hose between the pump and the muffler.

**⚠ WARNING** HAZARDOUS PRESSURE. Can result in serious injury or property damage. Do not service or clean pump, hoses or dispensing valve while the system is pressurized.

- Disconnect air supply line and relieve pressure from the system by opening dispensing valve or device and / or carefully and slowly loosening and removing outlet hose or piping from pump.

**⚠ WARNING** HAZARDOUS MATERIALS. Can cause serious injury or property damage. Do not attempt to return a pump to the factory or service center that contains hazardous material. Safe handling practices must comply with local and national laws and safety code requirements.

- Obtain Material Safety Data Sheets on all materials from the supplier for proper handling instructions.

**⚠ WARNING** EXPLOSION HAZARD. Models containing aluminum wetted parts cannot be used with 1,1,1-trichloroethane, methylene chloride or other halogenated hydrocarbon solvents which may react and explode.

- Check pump motor section, fluid caps, manifolds and all wetted parts to assure compatibility before using with solvents of this type.

**⚠ WARNING** MISAPPLICATION HAZARD. Do not use models containing aluminum wetted parts with food products for human consumption. Plated parts can contain trace amounts of lead.

**⚠ CAUTION** Verify the chemical compatibility of the pump wetted parts and the substance being pumped, flushed or recirculated. Chemical compatibility may change with temperature and concentration of the chemical(s) within the substances being pumped, flushed or circulated. For specific fluid compatibility, consult the chemical manufacturer.

**⚠ CAUTION** Maximum temperatures are based on mechanical stress only. Certain chemicals will significantly reduce maximum safe operating temperature. Consult the chemical manufacturer for chemical compatibility and temperature limits. Refer to PUMP DATA on page 1 of this manual.

**⚠ CAUTION** Be certain all operators of this equipment have been trained for safe working practices, understand it's limitations, and wear safety goggles / equipment when required.

**⚠ CAUTION** Do not use the pump for the structural support of the piping system. Be certain the system components are properly supported to prevent stress on the pump parts.

- Suction and discharge connections should be flexible connections (such as hose), not rigid piped, and should be compatible with the substance being pumped.

**⚠ CAUTION** Prevent unnecessary damage to the pump. Do not allow pump to operate when out of material for long periods of time.

- Disconnect air line from pump when system sits idle for long periods of time.

**⚠ CAUTION** Use only genuine ARO replacement parts to assure compatible pressure rating and longest service life.

**NOTICE** RE-TORQUE ALL FASTENERS BEFORE OPERATION. Creep of housing and gasket materials may cause fasteners to loosen. Torque all fasteners to ensure against fluid or air leakage.

<b>⚠ WARNING</b>	<b>= Hazards or unsafe practices which could result in severe personal injury, death or substantial property damage.</b>
<b>⚠ CAUTION</b>	<b>= Hazards or unsafe practices which could result in minor personal injury, product or property damage.</b>
<b>NOTICE</b>	<b>= Important installation, operation or maintenance information.</b>

---

## GENERAL DESCRIPTION

---

The ARO diaphragm pump offers high volume delivery even at low air pressure and a broad range of material compatibility options available. Refer to the model and option chart. ARO pumps feature stall resistant design, modular air motor / fluid sections.

Air operated double diaphragm pumps utilize a pressure differential in the air chambers to alternately create suction and positive fluid pressure in the fluid chambers, ball checks ensure a positive flow of fluid.

Pump cycling will begin as air pressure is applied and it will continue to pump and keep up with the demand. It will build and maintain line pressure and will stop cycling once maximum line pressure is reached (dispensing device closed) and will resume pumping as needed.

---

## AIR AND LUBE REQUIREMENTS

---

**⚠ WARNING EXCESSIVE AIR PRESSURE. Can cause pump damage, personal injury or property damage.**

- A filter capable of filtering out particles larger than 50 microns should be used on the air supply. There is no lubrication required other than the "O" ring lubricant which is applied during assembly or repair.
- If lubricated air is present, make sure that it is compatible with the "O" rings and seals in the air motor section of the pump.

---

## INSTALLATION

---

- Verify correct model / configuration prior to installation.
- Retorque all external fasteners per specifications prior to start up.
- Pumps are tested in water at assembly. Flush pump with compatible fluid prior to installation.
- When the diaphragm pump is used in a forced-feed (flooded inlet) situation, it is recommended that a "check valve" be installed at the air inlet.
- Material supply tubing should be at least the same diameter as the pump inlet manifold connection.
- Material supply hose must be reinforced, non-collapsible type compatible with the material being pumped.
- Piping must be adequately supported. Do not use the pump to support the piping.
- Use flexible connections (such as hose) at the suction and discharge. These connections should not be rigid piped and must be compatible with the material being pumped.
- Secure the diaphragm pump legs to a suitable surface (level and flat) to ensure against damage by vibration.

- Pumps that need to be submersed must have both wet and non-wet components compatible with the material being pumped.
- Submersed pumps must have exhaust pipe above liquid level. Exhaust hose must be conductive and grounded.
- Flooded suction inlet pressure must not exceed 10 psig (0.69 bar).

---

## OPERATING INSTRUCTIONS

---

- Always flush the pump with a solvent compatible with the material being pumped if the material being pumped is subject to "setting up" when not in use for a period of time.
- Disconnect the air supply from the pump if it is to be inactive for a few hours.

---

## PARTS AND SERVICE KITS

---

Refer to the part views and descriptions as provided on page 5 through 7 for parts identification and Service Kit information.

- Certain ARO "Smart Parts" are indicated which should be available for fast repair and reduction of down time.
- Service kits are divided to service two separate diaphragm pump functions: 1. AIR SECTION, 2. FLUID SECTION. The Fluid Section is divided further to match typical part Material Options.

---

## MAINTENANCE

---

- Provide a clean work surface to protect sensitive internal moving parts from contamination from dirt and foreign matter during service disassembly and reassembly.
- Keep good records of service activity and include pump in preventive maintenance program.
- Before disassembling, empty captured material in the outlet manifold by turning the pump upside down to drain material from the pump.

---

## FLUID SECTION DISASSEMBLY

---

1. Remove (61) outlet manifold, (60) inlet manifold.
2. Remove (22) balls, (19 and 33) "O" rings and (21) seats.
3. Remove (15) fluid caps.

**NOTE:** Only PTFE diaphragm models use a primary diaphragm (7) and a backup diaphragm (8). Refer to the auxiliary view in the Fluid Section illustration.

4. Remove the (6) diaphragm screw, (7) or (7 / 8) diaphragms, and (5) backup washer.

**NOTE:** Do not scratch or mar the surface of (1) diaphragm rod.

---

## FLUID SECTION REASSEMBLY

---

- Reassemble in reverse order. Refer to the torque requirements on page 6.
- Clean and inspect all parts. Replace worn or damaged parts with new parts as required.
- Lubricate (1) diaphragm rod and (144) "U" cup with Lubriplate FML-2 grease (94276 grease packet is included in service kit).

- For models with PTFE diaphragms: Item (8) Santoprene diaphragm is installed with the side marked "AIR SIDE" towards the pump center body. Install the PTFE diaphragm (7) with the side marked "FLUID SIDE" towards the (15) fluid cap.
- For PX20E-FNS-KTT (Conductive PVDF) models with PTFE diaphragms:
  - Pump is assembled with joint sealant from the factory as standard. Inspect joint sealant. If damaged,

apply Joint Sealant (Kit PN: 637545) to each air caps #68 and #69 diaphragm groove. Use only 1 wrap of sealant. DO NOT overlap seam, trim excess. Seam to be located between bolt position 1 and 8 (refer to "torque sequence" diagram on page 6).

- Re-check torque settings after pump has been re-started and run a while.

## PARTS LIST / PX20X-XXX-XXX-AXXX FLUID SECTION

### FLUID SECTION SERVICE KITS (637373-XXX OR 637373-XX)

★ **For Fluid Kits With Seats: 637373-XXX Fluid Section Service Kits include:** Seats (see SEAT Option, refer to -XXX in chart below), Balls (see BALL Option, refer to -XXX in chart below), Diaphragms (see DIAPHRAGM Option, refer to -XXX in chart below), and items 19, 33, 70, 144, 175, 237 and 238 (listed below) plus 174 and 94276 Lubriplate® FML-2 grease (page 7).

★ **For Fluid Kits Without Seats: 637373-XX Fluid Section Service Kits include:** Balls (see BALL Option, refer to -XX in chart below), Diaphragms (see DIAPHRAGM Option, refer to -XX in chart below), and items 19, 33, 70, 144, 175, 237 and 238 (listed below) plus 174 and 94276 Lubriplate® FML-2 grease (page 7).

### COMMON PARTS

Item	Description (size)	Qty	Part No.	Mtl	Item	Description (size)	Qty	Part No.	Mtl
1	Connecting Rod	(1)	97386	[C]	74	Pipe Plug (1/4-18 NPT x 0.41") (models PX20X-FXS-XXX-AXXX only) (see page 6)	(2)	Y17-51-S	[SS]
5	Backup Washer	(2)	94357-2	[SS]	131	Screw (M10 x 1.5 - 6g x 134 mm)	(6)	95920	[SS]
26	Screw (M10 x 1.5 - 6g x 45 mm)	(16)	95925	[SS]	★✓144	"U" Cup (3/16" x 1-3/8" OD)	(2)	Y186-51	[B]
27	Screw (M10 x 1.5 - 6g x 100 mm)	(28)	95922	[SS]	★✓175	"O" Ring (3/32" x 1" OD)	(2)	Y325-117	[B]
28	Washer (0.406" ID)	(44)	93360-1	[SS]	✓180	Washer (0.406" ID x 0.031" thick)	(6)	94098	[Co]
29	Flange Nut (M10 x 1.5 - 6g)	(28)	94992	[SS]	181	Roll Pin (5/32" OD x 3/4" long)	(4)	Y178-56-S	[SS]
43	Ground Lug (models PX20E only) (see page 8)	(1)	93004	[Co]	234	Threaded Tri-Plate	(2)	95737	[SS]
68	Air Cap (models PX20E)	(1)	95762-7	[GP]	235	Tri-Plate (inside item 68)	(2)	95736	[SS]
	(models PX20P)		95762-3	[VE]	★✓237	Track Gasket	(4)	95849	[B]
69	Air Cap (models PX20E)	(1)	95762-8	[GP]	★✓238	"O" Ring (3/32" x 5/8" OD)	(4)	Y325-111	[B]
	(models PX20P)		95762-4	[VE]	239	Roll Pin (5/32" OD x 1/2" long)	(2)	Y178-52-S	[SS]
★✓70	Gasket	(2)	94100	[B]					

✓ Indicate as items included in Air Section Service Kit, see page 7.

### SEAT OPTIONS PX20X-XXX-XXX-AXXX

★ "21"			
-XXX	Seat	Qty	Mtl
-KXX	95847-2	(4)	[K]
-PXX	95847-1	(4)	[P]

### BALL OPTIONS PX20X-XXX-XXX-AXXX

★ "22" (2-1/2" diameter)							
-XXX	Ball	Qty	Mtl	-XXX	Ball	Qty	Mtl
-XAX	93358-A	(4)	[Sp]	-XSX	94805	(4)	[SS]
-XCX	93358-C	(4)	[H]	-XTX	93358-4	(4)	[T]
-XGX	93358-2	(4)	[B]	-XVX	93358-3	(4)	[V]

### DIAPHRAGM OPTIONS PX20X-XXX-XXX-AXXX

-XXX	★ Service Kit With Seat	★ Service Kit Without Seat	★ "7"			★ "8"			★ "19" (3/16" x 4" OD)			★ "33" (3/16" x 5" OD)		
	-XXX = (Seat) -XXX = (Ball) -XXX = (Diaphragm)	-XX = (Ball) -XX = (Diaphragm)	Diaphragm	Qty	Mtl	Diaphragm	Qty	Mtl	"O" Ring	Qty	Mtl	"O" Ring	Qty	Mtl
-XXA	637373-XXA	637373-XA	94329-A	(2)	[SP]	-----	---	---	95912	(4)	[E]	94115	(4)	[E]
-XXC	637373-XXC	637373-XC	94329-C	(2)	[H]	-----	---	---	Y327-342	(4)	[V]	Y327-350	(4)	[V]
-XXG	637373-XXG	637373-XG	96330-2	(2)	[B]	-----	---	---	Y325-342	(4)	[B]	Y325-350	(4)	[B]
-XXL	637373-XXL	637373-XL	95930-L	(2)	[L]	94330-A	(2)	[SP]	95910	(4)	[T]	95909	(4)	[T]
-XXM	637373-XXM	637373-XM	94329-M	(2)	[MSP]	-----	---	---	95912	(4)	[E]	94115	(4)	[E]
-XXT	637373-XXT	637373-XT	95930	(2)	[T]	94330-A	(2)	[SP]	95910	(4)	[T]	95909	(4)	[T]
-XXV	637373-XXV	637373-XV	95344	(2)	[V]	-----	---	---	Y327-342	(4)	[V]	Y327-350	(4)	[V]

### MANIFOLD / FLUID CAP MATERIAL OPTIONS PX20X-XXX-XXX-AXXX

Item	Description (size)	Qty	Conductive Polypropylene		PVDF		Conductive PVDF		Polypropylene	
			PX20E-FES-XXX		PX20P-FKS-XXX		PX20E-FNS-XXX		PX20P-FPS-XXX	
			Part No.	Mtl	Part No.	Mtl	Part No.	Mtl	Part No.	Mtl
6	Diaphragm Screw	(2)	95858-1	[P]	95858-2	[K]	95858-2	[K]	95858-1	[P]
15	Fluid Cap	(2)	95855-3	[GP]	95855-2	[K]	95855-5	[GK]	95855-1	[P]
60	Inlet Manifold	(1)	95857-3	[GP]	95857-2	[K]	95857-5	[GK]	95857-1	[P]
61	Outlet Manifold	(1)	95856-3	[GP]	95856-2	[K]	95856-5	[GK]	95856-1	[P]

### MATERIAL CODE

[B]	= Nitrile
[C]	= Carbon Steel
[Co]	= Copper
[E]	= E.P.R.
[GK]	= Groundable PVDF
[GP]	= Groundable Polypropylene
[H]	= Hytrel®
[K]	= PVDF
[L]	= Long Life PTFE
[MSP]	= Medical Grade Santoprene®
[P]	= Polypropylene
[SP]	= Santoprene®
[SS]	= Stainless Steel
[T]	= PTFE
[V]	= Viton®
[VE]	= Vinyl Ester

COLOR CODE		
MATERIAL	DIAPHRAGM COLOR	BALL COLOR
Hytre®	Cream	Cream
Nitrile	Black	Red (*)
Santoprene®	Tan	Tan
Santoprene® (Backup)	Green	N/A
PTFE	White	White
Viton®	Yellow (-)	Yellow (*)
	(-) Dash	(*) Dot

FOR THE AIR MOTOR SECTION SEE PAGES 7 AND 8

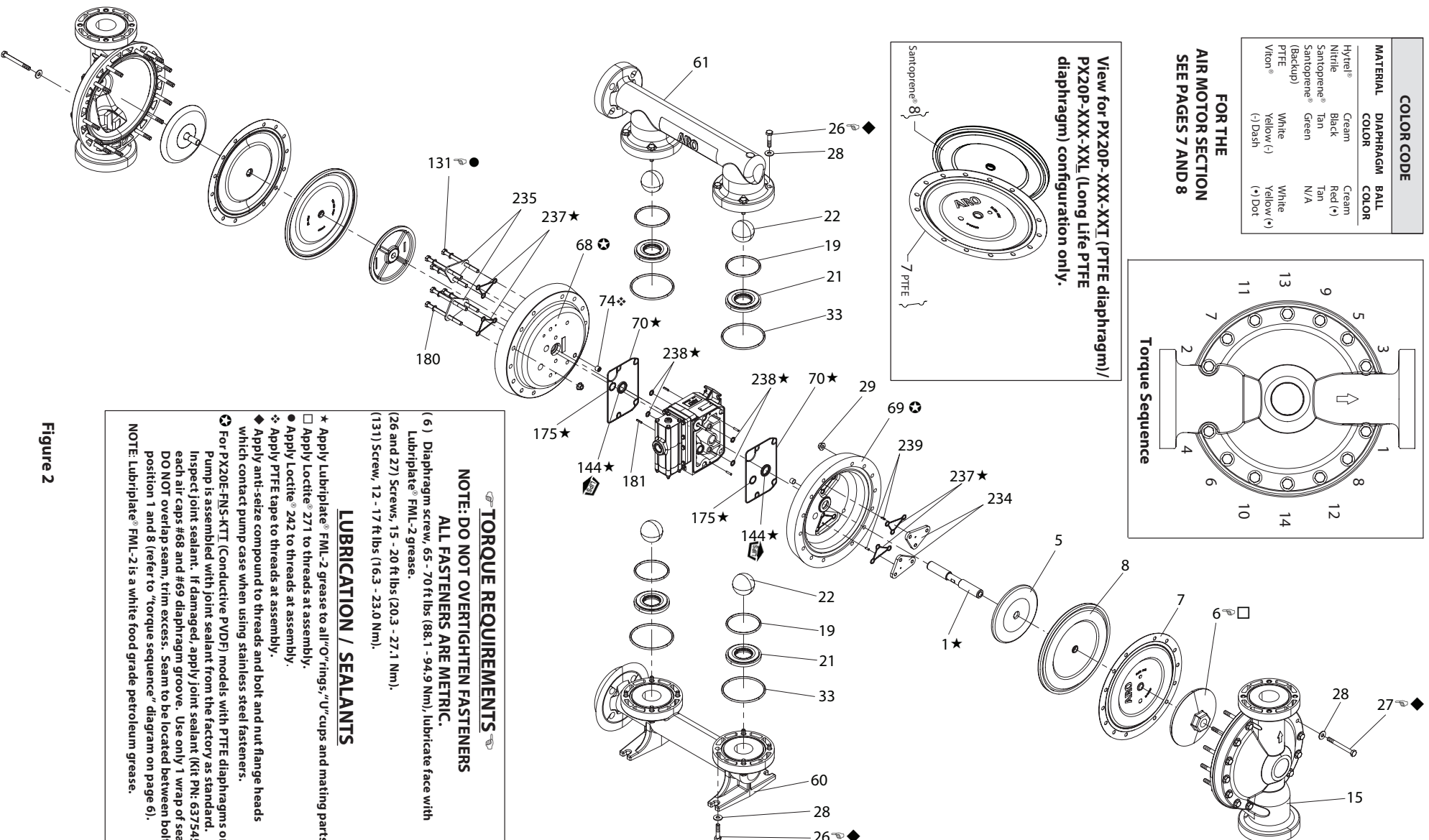
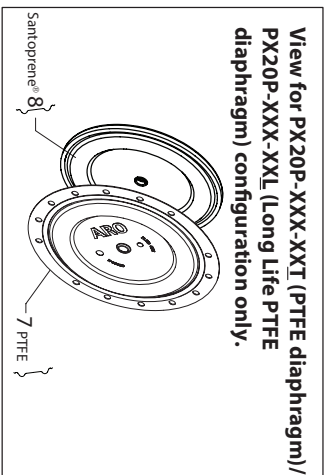
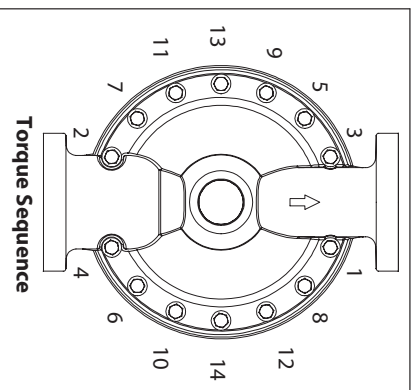

**TORQUE REQUIREMENTS**

**NOTE: DO NOT OVERTIGHTEN FASTENERS**

**ALL FASTENERS ARE METRIC.**

- (6) Diaphragm screw, 65 - 70 ft lbs (88.1 - 94.9 Nm), lubricate face with Lubriplate® FML-2 grease.
- (26 and 27) Screws, 15 - 20 ft lbs (20.3 - 27.1 Nm).
- (131) Screw, 12 - 17 ft lbs (16.3 - 23.0 Nm).

**LUBRICATION / SEALANTS**

- \* Apply Lubriplate® FML-2 grease to all "O" rings, "U" cups and mating parts.
- Apply Loctite® 271 to threads at assembly.
- Apply Loctite® 242 to threads at assembly.
- ◆ Apply PTFE tape to threads at assembly.
- ◆ Apply anti-seize compound to threads and bolt and nut flange heads which contact pump case when using stainless steel fasteners.
- ⊗ For PX20E-FMS-KIT (Conductive PVDF) models with PTFE diaphragms only: Pump is assembled with joint sealant from the factory as standard. Inspect joint sealant. If damaged, apply joint sealant (Kit PN: 637545) to each air caps #68 and #69 diaphragm groove. Use only 1 wrap of sealant. DO NOT overlap seam, trim excess. Seam to be located between bolt position 1 and 8 (refer to "torque sequence" diagram on page 6).
- NOTE: Lubriplate® FML-2 is a white food grade petroleum grease.

Figure 2

## PARTS LIST / PX20X-XXX-XXX-AXXX AIR SECTION

✓ Indicates parts included in 637369 Air Section Service Kit shown below and items (70), (144), (175), (180), (237) and (238) shown on page 5.  
 ★ Indicates items included in Fluid Section Service Kit, see page 5.

### AIR MOTOR PARTS LIST

Item	Description (size)	Qty	Part No.	Mtl
101	Center Body (PX20E)	(1)	97044	[GP]
	(PX20P)	(1)	97037	[P]
103	Bushing	(1)	97394	[D]
105	Screw (M6 x 1 - 6g x 180 mm)	(4)	95921	[SS]
107	End Plate	(2)	95846	[SS]
111	Spool	(1)	95651	[D]
118	Actuator Pin (0.250" x 2.276" long)	(2)	94083	[SS]
121	Sleeve	(2)	94084	[D]
126	Pipe Plug	(1)	93897-1	[GFP]
127	90° St. Elbow (1-1/2 - 11-1/2 NPT)	(1)	94860	[C/I]
✓132	Gasket	(1)	94099	[B]
133	Washer (M6) (PX 20E)	(7)	95931	[SS]
	(PX20P)	(8)		
134	Screw (M6 x 1 - 6g x 35 mm)	(8)	95923	[SS]
135	Valve Block (PX20P)	(1)	95789	[P]
	(PX20E)	(1)	95789-2	[GP]
136	End Cap	(1)	95790	[P]
✓137	"O" Ring (1/16" x 2" OD)	(1)	Y325-32	[B]
✓138	"U" Cup (3/16" x 1.792" OD)	(1)	95966	[B]
✓139	"U" Cup (3/16" x 1/4" OD)	(1)	Y186-50	[B]
140	Valve Insert	(1)	95650	[AO]
141	Valve Plate	(1)	95659	[AO]
✓146	"O" Ring (1/8" x 7/8" OD)	(1)	Y325-208	[B]
✓147	"O" Ring (1/8" x 5/8" OD)	(1)	Y325-204	[B]
✓166	Track Gasket	(1)	94026	[B]

Item	Description (size)	Qty	Part No.	Mtl
✓167	Pilot Piston (includes 168 and 169)	(1)	67164	[D]
168	"O" Ring (3/32" x 5/8" OD)	(2)	94433	[U]
169	"U" Cup (1/8" x 7/8" OD)	(1)	Y240-9	[B]
170	Piston Sleeve	(1)	94081	[D]
✓171	"O" Ring (3/32" x 1-1/8" OD)	(1)	Y325-119	[B]
✓172	"O" Ring (1/16" x 1-1/8" OD)	(1)	Y325-22	[B]
✓173	"O" Ring (1/16" x 1-3/8" OD)	(2)	Y325-26	[B]
★✓174	"O" Ring (1/8" x 1/2" OD)	(2)	Y325-202	[B]
✓176	Diaphragm (check valve)	(2)	94102	[SP]
✓199	Track Gasket	(1)	95666	[B]
✓200	Gasket	(1)	95665	[B]
201	Muffler (includes item 127)	(1)	67213	
201	Muffler (Optional)	(1)	94117	
✓232	"O" Ring (1/8" x 1/2" OD)	(2)	Y325-202	[B]
233	Adapter Plate	(1)	95761	[P]
236	Nut (M6 x 1 - 6g)	(4)	95924	[SS]
★✓	Lubriplate® FML-2 Grease	(1)	94276	
	Lubriplate® Grease Packets (10)		637308	

MATERIAL CODE	
[AO]	= Alumina Oxide
[B]	= Nitrile
[C]	= Carbon Steel
[D]	= Acetal
[GP]	= Glass Filled Polypropylene
[GFP]	= Groundable Polypropylene

MATERIAL CODE	
[I]	= Iron
[P]	= Polypropylene
[SP]	= Santoprene®
[SS]	= Stainless Steel
[U]	= Polyurethane

### AIR MOTOR SECTION SERVICE

Service is divided into two parts – 1. Pilot Valve, 2. Major Valve. GENERAL REASSEMBLY NOTES:

- Air Motor Section Service is continued from Fluid Section repair.
- Inspect and replace old parts with new parts as necessary. Look for deep scratches on surfaces, and nicks or cuts in "O" rings.
- Take precautions to prevent cutting "O" rings upon installation.
- Lubricate "O" rings with Lubriplate® FML-2 grease.
- Do not over-tighten fasteners, refer to torque specification block on view.
- Torque fasteners following restart.
- SERVICE TOOLS – To aid in the installation of (168) "O" rings onto the (167) pilot piston, use tool # 204130-T, available from ARO.

#### PILOT VALVE DISASSEMBLY

1. A light tap on (118) should expose the opposite (121) sleeve, (167) pilot piston and other parts.
2. Remove (170) sleeve, inspect inner bore of sleeve for damage.

#### PILOT VALVE REASSEMBLY

1. Clean and lubricate parts not being replaced from service kit.
2. Install new (171 and 172) "O" rings, replace (170) sleeve.
3. Install new (168) "O" rings and (169) "U" cup. Note the lip direction. Lubricate and replace (167) pilot piston.
4. Reassemble remaining parts, replace (173 and 174) "O" rings.

### MAJOR VALVE DISASSEMBLY

1. Remove (135) valve block and (233) adapter plate, exposing (132 and 166) gaskets, (232) "O" ring and (176) checks.
2. Remove (233) adapter plate, releasing (140) valve insert, (141) valve plate, (199 and 200) gaskets and (146, 147 and 232) "O" rings.
3. Remove (136) end cap and (137) "O" ring, releasing (111) spool.

### MAJOR VALVE REASSEMBLY

1. Install new (138 and 139) "U" cups on (111) spool – **LIPS MUST FACE EACH OTHER.**
2. Insert (111) spool into (135) valve block.
3. Install (137) "O" ring on (136) end cap and assemble end cap to (135) valve block, securing with (107) end plates and (105) screws.

**NOTE:** Tighten (105) screws to 35 - 40 in. lbs (4.0 - 4.5 Nm).

4. Install (140) valve insert and (141) valve plate into (135) valve block.

**NOTE:** Assemble (140) valve insert with "dished" side toward (141) valve plate. Assemble (141) valve plate with 2 identification dots toward (199 and 200) gaskets.

5. Assemble (146, 147 and 232) "O" rings, (199 and 200) gaskets and (233) adapter plate to (135) valve block.
6. Assemble (132 and 166) gaskets, (176) checks and (232) "O" ring to (101) body.
7. Assemble (135) valve block and components to (101) body, securing with (134) screws.

**NOTE:** Tighten (134) screws to 35 - 40 in. lbs (4.0 - 4.5 Nm).

# PARTS LIST / PX20X-XXX-XXX-AXXX AIR SECTION

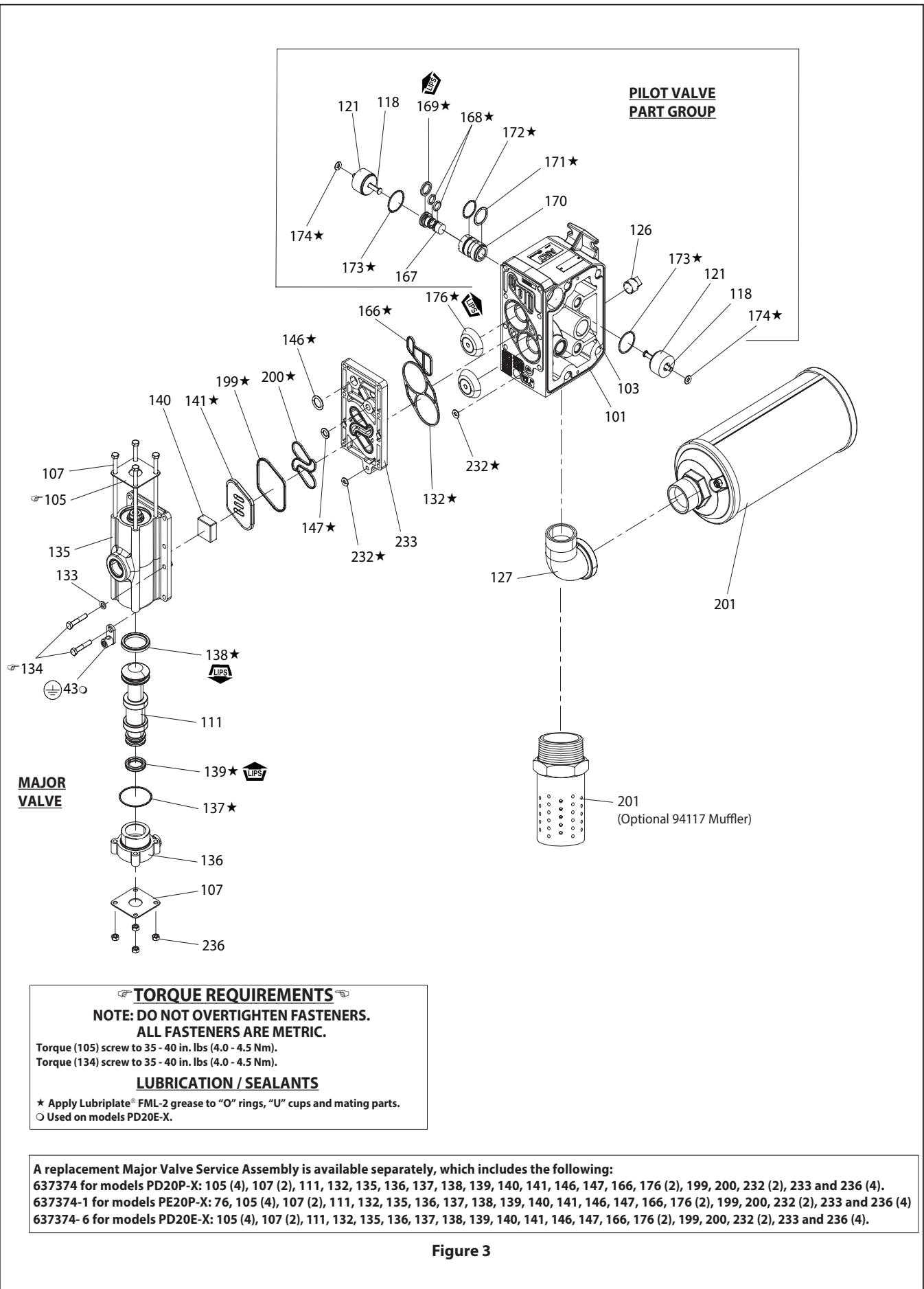

Figure 3

## TROUBLESHOOTING

### Product discharged from exhaust outlet.

- Check for diaphragm rupture.
- Check tightness of (6) diaphragm screw.

### Air bubbles in product discharge.

- Check connections of suction plumbing.
- Check "O" rings between intake manifold and inlet side fluid caps.
- Check tightness of (6) diaphragm screw.

### Motor blows air or stalls.

- Check (176) check valve for damage or wear.
- Check for restrictions in valve / exhaust.

### Low output volume, erratic flow, or no flow.

- Check air supply.
- Check for plugged outlet hose.
- Check for kinked (restrictive) outlet material hose.
- Check for kinked (restrictive) or collapsed inlet material hose.
- Check for pump cavitation – suction pipe should be sized at least as large as the inlet thread diameter of the pump for proper flow if high viscosity fluids are being pumped. Suction hose must be a non-collapsing type, capable of pulling a high vacuum.
- Check all joints on the inlet manifolds and suction connections. These must be air tight.
- Inspect the pump for solid objects lodged in the diaphragm chamber or the seat area.

## DIMENSIONAL DATA

