

Instructions – Parts List



ALUMINUM

Husky™ 3275 Air-Operated Diaphragm Pump

308639L

ENG

3-inch pump for fluid transfer applications. For professional use only.

120 psi (0.8 MPa, 8 bar) Maximum Incoming Air Pressure
120 psi (0.8 MPa, 8 bar) Maximum Fluid Working Pressure

*** Part No. DK3XXX**

Part No. 232505 Private-Label Aluminum 3275 Pump (See page 20.)

Part No. 24D619 Private-Label Aluminum 3275 Pump (See page 20.)

* This model is  certified.

US and Foreign Patents Pending



Important Safety Instructions

Read all warning and instructions in this manual. Save these instructions.

Refer to the Pump Matrix on page 20 to determine the Part No. of your pump.

Contents

Warnings	2
Installation	4
Operation	9
Maintenance	10
Troubleshooting	11
Service	12
Pump Matrix	20
Repair Kit Matrix	21
Parts Drawing	22
Parts Lists	23
Technical Data	24
Torque Sequence	25
Dimensional Drawings	26
Performance Charts	27
Graco Standard Warranty	30
Graco Information	30

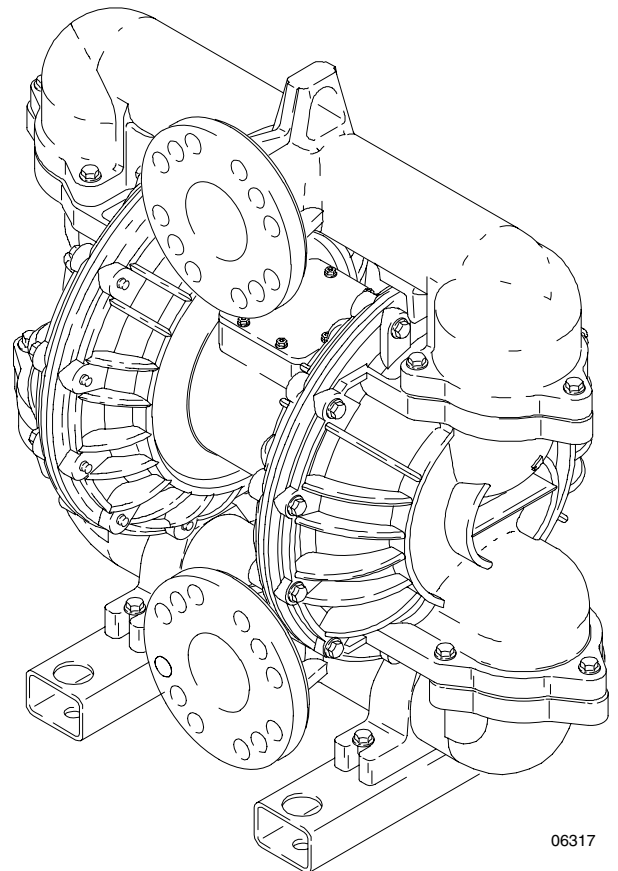

06317



PROVEN QUALITY. LEADING TECHNOLOGY.

Warnings

Warning Symbol



This symbol alerts you to the possibility of serious injury or death if you do not follow the instructions.

Caution Symbol



This symbol alerts you to the possibility of damage to or destruction of equipment if you do not follow the instructions.

! WARNING



INSTRUCTIONS

EQUIPMENT MISUSE HAZARD

Any misuse of the equipment or accessories, such as overpressurizing, modifying parts, using incompatible chemicals and fluids, or using worn or damaged parts, can cause them to rupture and result in splashing in the eyes or on the skin, other serious injury, or fire, explosion or property damage.

- This equipment is for professional use only. Observe all warnings. Read and understand all instruction manuals, warning labels, and tags before you operate the equipment.
- Never alter or modify any part of this equipment; doing so could cause it to malfunction. Use only genuine Graco parts and accessories.
- Check all equipment regularly and repair or replace worn or damaged parts immediately.
- Never exceed the recommended working pressure or the maximum air inlet pressure stated on your pump or in the **Technical Data** on page 24.
- Do not exceed the maximum working pressure of the lowest rated component in your system. This equipment has a **120 psi (0.8 MPa, 8 bar) maximum working pressure at 120 psi (0.8 MPa, 8 bar) maximum incoming air pressure.**
- Be sure that all fluids and solvents used are chemically compatible with the wetted parts shown in the **Technical Data** on page 24. Always read the manufacturer's literature before you use fluid or solvent in the pump.
- Never move or lift a pump under pressure. If dropped, the fluid section may rupture. Always follow the **Pressure Relief Procedure** on page 9 before you move or lift the pump.
- The pump weighs approximately 150 lb (68 kg) If it must be moved, use the lift ring, or have two people lift the pump by grasping the outlet manifold.

⚠ WARNING



HAZARDOUS FLUIDS

Improper handling of hazardous fluids or inhaling toxic vapors can cause extremely serious injury or death from to splashing in the eyes, ingestion, or bodily contamination. Observe all the following precautions when handling known or potentially hazardous fluids.

- Know what fluid you are pumping and its specific hazards. Take precautions to avoid a toxic fluid spill.
- Always wear appropriate clothing and equipment, such as eye protection and breathing apparatus, to protect yourself.
- Store hazardous fluid in an appropriate, approved container. Dispose of it according to all Local, State and Federal guidelines for hazardous fluids.
- Secure the fluid outlet hose tightly into the receiving container to prevent it from coming loose and improperly draining the fluid.
- Pipe and dispose of the exhaust air safely, away from people, animals, and food handling areas. If the diaphragm fails, the fluid is exhausted along with the air. See **Air Exhaust Ventilation** on page 7.



FIRE AND EXPLOSION HAZARD

Static electricity is created by the flow of fluid through the pump and hose. If the equipment is not properly grounded, sparking may occur. Sparks can ignite fumes from solvents and the fluid being pumped, dust particles, and other flammable substances, whether you are pumping indoors or outdoors, and can cause a fire or explosion and serious injury and property damage.

- To reduce the risk of static sparking, ground the pump and all other equipment used or located in the work area. Check your local electrical code for detailed grounding instructions for your area and type of equipment. Refer to **Grounding** on page 4.
- If you experience any static sparking or even a slight shock while using this equipment, **stop pumping immediately**. Check the entire system for proper grounding. Do not use the system again until the problem has been identified and corrected.
- Pipe and dispose of the exhaust air safely, away from all sources of ignition. If the diaphragm fails, the fluid is exhausted along with the air. See **Air Exhaust Ventilation** on page 7.
- Do not smoke in the work area. Do not operate the equipment near a source of ignition or an open flame, such as a pilot light.



HALOGENATED HYDROCARBON HAZARD

Never use 1,1,1-trichloroethane, methylene chloride, other halogenated hydrocarbon solvents or fluids containing such solvents in aluminum pumps. Such use could result in a serious chemical reaction, with the possibility of explosion, which could cause death, serious injury, and/or substantial property damage.

Consult your fluid suppliers to ensure that the fluids used are compatible with aluminum parts.

United States Government safety standards have been adopted under the Occupational Safety and Health Act. You should consult these standards—particularly the General Standards, Part 1910, and the Construction Standards, Part 1926.

Installation

General Information

- The Typical Installation shown in Fig. 2 is only a guide for selecting and installing system components. Contact your Graco distributor for assistance in planning a system to suit your needs.
- Always use genuine Graco parts and accessories.
- Reference numbers and letters in parentheses refer to the callouts in the figures and in the **Parts Drawing** on page 22 and the **Parts Lists** on pages 23 and 24.

⚠ WARNING

HAZARDOUS FLUIDS
To reduce the risk of serious injury, splashing in the eyes or on the skin, and toxic fluid spills, **never** move or lift a pump under pressure. If dropped, the fluid section could rupture. Always follow the **Pressure Relief Procedure** on page 9 before you move or lift the pump.

- The pump is very heavy. If it must be moved, have two people lift the pump by grasping the outlet manifold (50). See the Parts Drawing on page 22.

Use a compatible thread sealant on all male threads. Tighten all connections firmly to avoid air or fluid leaks.

⚠ CAUTION

To avoid pump damage, do not overtighten the fittings to the pump.

Tightening Screws Before First Use

Before using the pump for the first time, check and retorque all external fasteners. See **Torque Sequence**, page 25. After the first day of operation, retorque the fasteners. Although pump use varies, a general guideline is to retorque fasteners every two months.

Grounding

⚠ WARNING

ELECTRIC SHOCK HAZARD
This pump must be grounded. The steps for grounding may differ from the way you ground other pumps. Read and carefully follow the grounding instructions below before you operate the pump.

To reduce the risk of static sparking, ground the pump and all other equipment used or located in the pumping area. Check your local electrical code for detailed grounding instructions for your area and type of equipment.

Ground all of this equipment:

- *Pump:* Connect a ground wire and clamp as shown in Fig. 1. Loosen the grounding lug locknut (W) and washer (X). Insert one end of a 12 ga (1.5 mm²) minimum ground wire (Y) into the slot in the lug (Z), and tighten the locknut securely. Connect the clamp end of the ground wire to a true earth ground. *To order a ground wire and clamp, order Part No. 222011.*

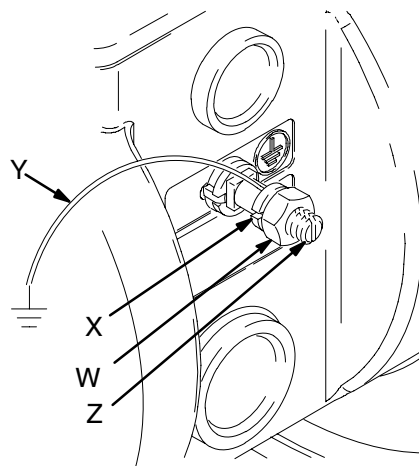

Fig. 1

06318

- *Air compressor:* Follow the manufacturer's recommendations.
- *Air and fluid hoses:* Use only grounded hoses with a maximum of 500 ft (150 m) combined hose length to ensure grounding continuity.
- *All solvent pails used when flushing:* Follow the local code. Use only metal pails, which are conductive. Do not place the pail on a non-conductive surface, such as paper or cardboard, which interrupts grounding continuity.
- *Fluid supply container:* Follow the local code.

Installation

FLOOR-MOUNT TYPICAL INSTALLATION

KEY

- A Air supply hose
- B Bleed-type master air valve (required for pump)
- C Air regulator
- D Air line quick disconnect
- E Master air valve (for accessories)
- F Air line filter
- G Fluid suction hose
- H Fluid supply
- J Ball valve (for releasing collected moisture)
- L Fluid outlet hose
- N Air inlet port
- R Fluid inlet port
- S Fluid outlet port
- Y Ground wire (required; see page 4 for installation instructions)

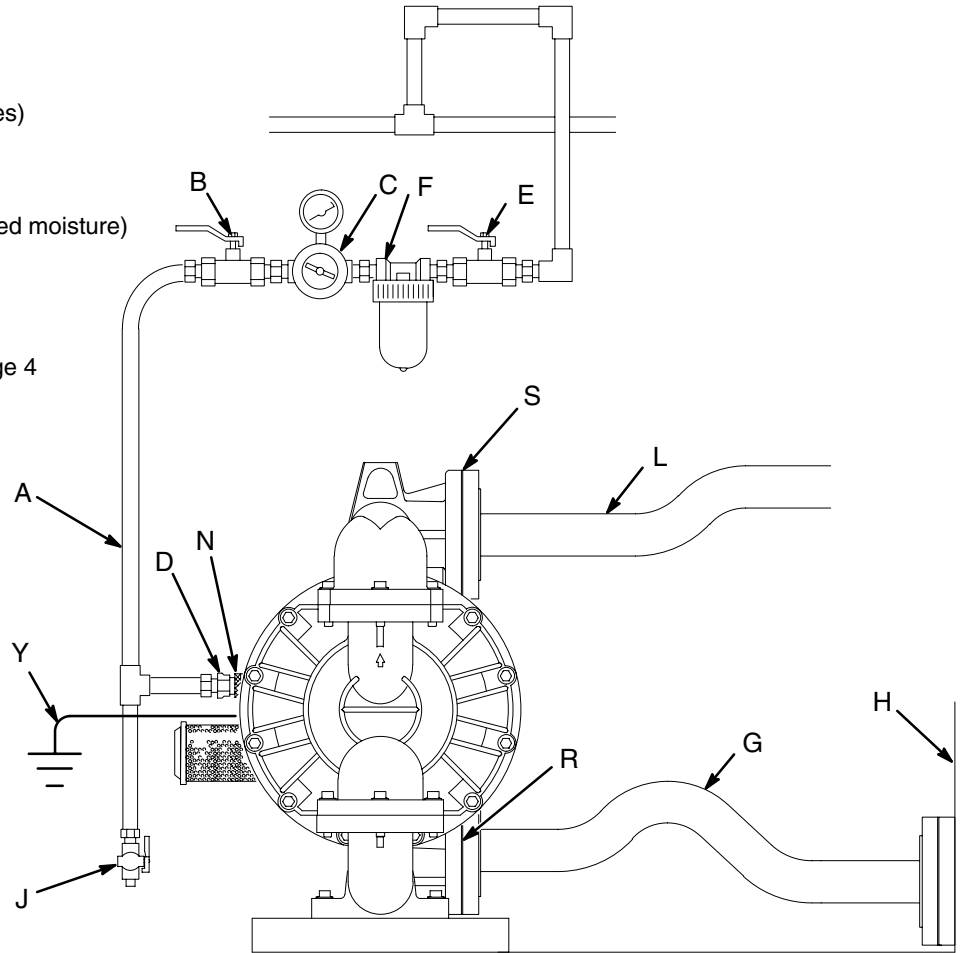

Fig. 2

06319

Installation

Mountings

CAUTION

The pump exhaust air may contain contaminants. Ventilate to a remote area if contaminants could affect your fluid supply. See **Air Exhaust Ventilation** on page 7.

- Be sure the mounting can support the weight of the pump, hoses, and accessories, as well as the stress caused during operation.
- For all mountings, be sure the pump is secured with screws through the mounting feet (58). See the mounting feet in the **Parts Drawing** on page 22.

Air Line

WARNING

A bleed-type master air valve and a fluid drain valve are required on your system.

The bleed-type master air valve relieves air trapped between itself and the pump. Trapped air can cause the pump to cycle unexpectedly, which could result in serious bodily injury, including splashing in the eyes, injury from moving parts, or contamination from hazardous fluids.

The fluid drain valve reduces the risk of serious bodily injury, including splashing in the eyes or on the skin, or contamination from hazardous fluids. Install the fluid drain valve close to the pump's fluid outlet to relieve pressure in the hose if the hose becomes plugged.

1. Mount the air line accessories on the wall or on a bracket. Be sure the air line supplying the accessories is grounded.
 - a. The pump speed can be controlled in one of two ways: To control it on the air side, install an air regulator. To control it on the fluid side, install a fluid valve near the outlet.
 - b. Install a bleed-type master air valve downstream from the air regulator, and use it to relieve trapped air. See the **WARNING**, above. Locate another bleed-type master air valve upstream from all air line accessories, and use it to isolate the accessories during cleaning and repair.
 - c. The air line filter removes harmful dirt and moisture from the compressed air supply.

2. Install a flexible air hose between the accessories and the pump air inlet. Screw the air line fitting into the air inlet.
3. Do not restrict the exhaust port. Excessive exhaust restriction can cause erratic pump operation.

Fluid Lines

WARNING

Graco always recommends that you use grounded fluid hoses to dissipate static electricity. When pumping non-conductive flammable fluids, grounded fluid hoses are required. See **Fire and Explosion Hazard** on page 3.

Fluid Outlet Line

1. Attach the fluid outlet hose to the fluid outlet flange by using a 3-in. ANSI or DIN flanged hose or pipe.
2. Install a fluid drain valve near the fluid outlet. See the **WARNING** in the **Air Line** section at left.

Fluid Suction Line

Attach the fluid suction hose to the pump fluid inlet flange by using a 3-in. ANSI or DIN flanged fluid suction hose or pipe.

- If the inlet pressure to the pump is more than 25 percent of the outlet working pressure, the ball check valves do not close fast enough, which results in inefficient pump operation.
- At inlet fluid pressures over 15 psi (100 kPa, 1.0 bar), diaphragm life is shortened.
- The maximum suction lift is 8 ft (2.5 m) of water dry or 28 ft (8.5 m) of water wet. For suction lifts between 8 ft (2.5 m) and 28 ft (8.5 m) of water, it is necessary to install a foot valve, and it is necessary to flood the suction to prime the pump. The pump may prime better if you reduce the inlet air pressure until the pump is primed.

Installation

Changing Manifold Orientation

(See Fig. 6 on page 14)

The outlet manifold (50) and inlet manifold (53) can be rotated to best suit your installation needs. The pump is shipped with the inlet and outlet facing in the same direction.

1. Remove the screws (54) from each end of the manifold (50 or 53).
2. Turn the manifold to the desired position, and reinstall the screws (54). Torque to 55 to 60 ft-lb (75 to 81 N•m). See **Torque Sequence**, page 25.

NOTE: To ensure proper seating, visually check that the manifold is centered on the fluid covers (51) before you tighten the screws (54).

Fluid Pressure Relief Valve

CAUTION

Some systems may require installation of a pressure relief capability at the pump outlet to prevent overpressurization and rupture of the pump or hose.

Thermal expansion of fluid in the outlet line can cause overpressurization if the fluid line is close ended. Such overpressurization can occur when using long fluid lines exposed to sunlight or ambient heat, or when pumping from a cool to a warm area (for example, from an underground tank).

Air Exhaust Ventilation

WARNING



TOXIC FLUID HAZARD

Be sure to read and follow the **USING HAZARDOUS FLUIDS**, and **FIRE OR EXPLOSION HAZARD** warnings on page 3, before you operate this pump.



Be sure the system is properly ventilated for your type of installation. You must vent the exhaust to a safe place, away from people, animals or food handling areas when pumping flammable or hazardous fluids.



The minimum size for the air exhaust hose is 1 in. (25.4 mm) ID x 5 ft. (1.5 m). If a longer hose is required, use a larger diameter hose. Avoid sharp bends or kinks in the hose.

If the diaphragm ruptures, the fluid being pumped will be exhausted with the air. Place a container at the end of the air exhaust line to catch fluid in case the diaphragm ruptures.

The air exhaust port is 1 npt(f). Do not restrict the air exhaust port. Excessive exhaust restriction can cause erratic pump operation.

To provide a remote exhaust:

1. Remove the muffler (60) from the pump air exhaust port.
2. Install a grounded air exhaust hose (T) and connect the muffler (60) to the other end of the hose. The minimum size for the air exhaust hose is 1 in. (25.4 mm) ID x 5 ft (1.5 m). If a longer hose is required, use a larger diameter hose. Avoid sharp bends or kinks in the hose. See Fig. 3.
3. Place a container (U) at the end of the air exhaust line to catch fluid in case a diaphragm ruptures.

Installation

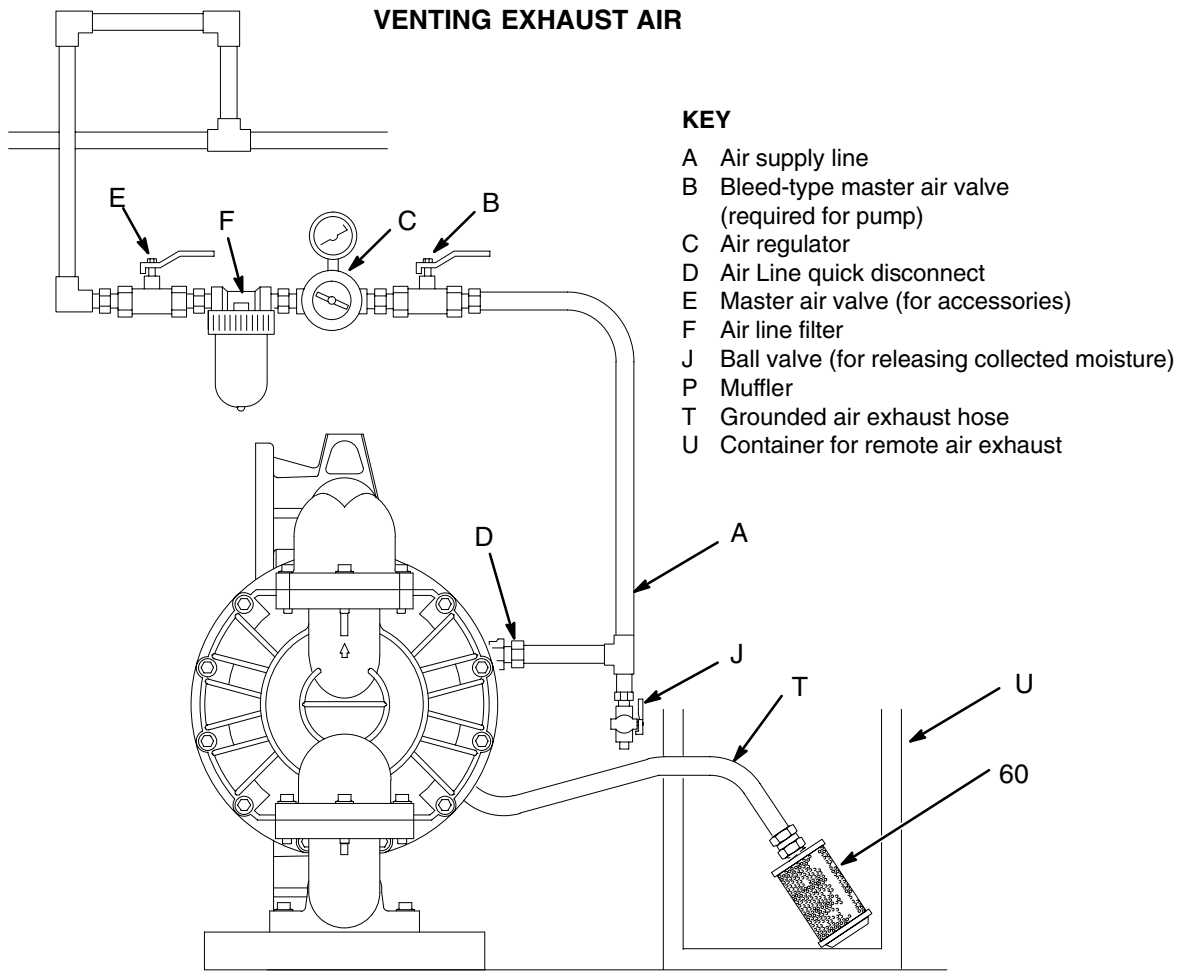

Fig. 3

06321

Operation

Pressure Relief Procedure

WARNING

To reduce the risk of serious injury, including splashing fluid in the eyes or on the skin, follow this procedure whenever you are instructed to relieve pressure, when you shut off the pump, and before you check, adjust, clean, move, or repair any system equipment.

1. Shut off the air to the pump.
2. Open any available outbound fluid valves to relieve fluid pressure from the pump.
3. If fluid is still in the outbound fluid lines, isolate this fluid as follows:
 - a. Close the outbound fluid valves.
 - b. Slowly remove the fluid connections from the pump, and have a container ready to catch any fluid that runs out.

Flush the Pump Before First Use

The pump was tested in water. If water could contaminate the fluid you are pumping, flush it thoroughly with a compatible solvent. Follow the procedure in **Starting and Adjusting the Pump**.

Starting and Adjusting the Pump

WARNING

To reduce the risk of serious injury, splashing in the eyes or on the skin, and toxic fluid spills, **never** move or lift a pump under pressure. If the pump is dropped, the fluid section could rupture. Always follow the **Pressure Relief Procedure** above before you move or lift the pump.

1. Be sure the pump is properly grounded. Read and follow the instructions in **Grounding** on page 4.
2. Check all fittings to be sure they are tight. Be sure to use a compatible liquid thread sealant on all male threads.

3. Place the suction tube (if used) in the fluid to be pumped.

NOTE: If the inlet pressure to the pump is more than 25 percent of the outlet working pressure, the ball check valves will not close fast enough, resulting in inefficient pump operation.

4. Place the end of the outlet hose into an appropriate container.
5. Close the fluid drain valve.
6. With the air regulator closed, open all bleed-type master air valves.
7. If the outlet hose has a dispensing device, hold it open while continuing with step 8.
8. Slowly open the air regulator until the pump starts to cycle. Allow the pump to cycle slowly until all air is pushed out of the lines and the pump is primed.

If you are flushing, run the pump long enough to thoroughly clean the pump and hoses, close the air regulator, and remove the suction hose from the solvent and place it in the fluid to be pumped.

If you are shutting down the pump, remove the suction hose from the fluid container, run the pump until the fluid is forced out of the system, and shut off the air supply immediately.

If you are going to use the pump, start the pump again, and place the suction hose in the supply container.

Pump Shutdown

At the end of the work shift and before checking, adjusting, cleaning, or repairing the system, **relieve the pressure**.

WARNING

To reduce the risk of serious injury whenever you are instructed to relieve pressure, always follow the **Pressure Relief Procedure** at left.

Maintenance

Lubrication

The air valve is designed to operate unlubricated.

If lubrication is desired, every 500 hours of operation (or monthly), remove the hose from the pump air inlet and add two drops of machine oil to the air inlet.

CAUTION

Do not over-lubricate the pump. Excess oil is exhausted through the muffler, which could contaminate your fluid supply or other equipment.

Flushing and Storage

Flush the pump often enough to prevent the fluid you are pumping from drying or freezing in the pump and damaging it. Always flush the pump and **relieve the pressure** before storing it for any length of time. Use a compatible solvent.

WARNING

To reduce the risk of serious injury whenever you are instructed to relieve pressure, always follow the **Pressure Relief Procedure** on page 9.

Tightening Connections

Before each use, check all hoses for wear or damage, and replace them as necessary. Check to be sure all connections are tight and leak free. Check fasteners. Tighten or retorque as necessary. Although pump use varies, a general guideline is to retorque fasteners every two months. See **Torque Sequence**, page 25.

Preventive Maintenance Schedule

Establish a preventive maintenance schedule, based on the pump's service history. This is especially important for prevention of spills or leakage due to diaphragm failure.

Troubleshooting

⚠ WARNING

To reduce the risk of serious injury, including splashing fluid in the eyes or on the skin, follow the **Pressure Relief Procedure** on page 9. You must do this whenever this manual instructs you to relieve pressure, when you shut off the pump, and before checking, adjusting, cleaning, moving, or repairing any system equipment.

NOTE: Check all possible problems and causes before you disassemble the pump.

PROBLEM	CAUSE	SOLUTION
Pump cycles at stall or fails to hold pressure at stall.	Worn check valve balls (201), seats (101) or o-rings (102).	Replace. See page 14.
Pump will not cycle, or cycles once and stops.	Air valve is stuck or dirty.	Disassemble and clean air valve. See pages 12 to 13. Use filtered air.
	Check valve ball (201) severely worn and wedged in seat (101) or manifold (50 or 53).	Replace ball and seat. See page 14.
	Check valve ball (201) is wedged into seat (101), due to overpressurization.	Install a pressure relief valve (see page 7).
	Dispensing valve is clogged.	Relieve pressure and clear valve.
Pump operates erratically.	Suction line is clogged.	Inspect; clear.
	Sticky or leaking check valve balls (201).	Clean or replace. See page 14.
	Diaphragm (301) is ruptured.	Replace. See pages 15 to 17.
	Restricted exhaust.	Remove restriction.
Air bubbles in fluid.	Suction line is loose.	Tighten.
	Diaphragm (301) is ruptured.	Replace. See pages 15 to 17.
	Loose inlet manifold (53), damaged seal between manifold and seat (101), or damaged o-rings (101).	Tighten manifold bolts (54), or replace seats (101) or o-rings (102). See page 14.
	Loose diaphragm shaft bolt (14).	Tighten or replace. See pages 15 to 17.
	Damaged o-ring (102).	Replace. See pages 15 to 17.
Fluid in exhaust air.	Diaphragm (301) is ruptured.	Replace. See pages 15 to 17.
	Loose diaphragm shaft bolt (14).	Tighten or replace. See pages 15 to 17.
	Damaged o-ring (102).	Replace. See pages 15 to 17.
Pump leaks air externally.	Air valve cover screws (3) are loose.	Tighten screws. See page 13.
	Air valve gasket (20) or air cover gasket (10) is damaged.	Inspect; replace. See pages 12 to 13, 18 to 19.
Pump leaks fluid externally from ball check valves.	Loose manifolds (50 or 53), damaged o-ring (102) between manifold and seat.	Tighten manifold bolts (54), or replace o-rings (102). See page 14.

Service

Repairing the Air Valve

Tools Required

- Torque wrench
- 7-mm or 9/32-in. socket wrench or Torx® screwdriver T20
- Needle-nose pliers
- O-ring pick
- Lithium-base grease, Part No. 111920 (Lubriplate 630AA or equivalent)

NOTE: Air Valve Service Kit 238765 is available. Parts included in the Air Valve Service Kit are marked with a symbol in the **Air Motor Parts List**, for example (3†). See page 23. Use all the parts in the kit for the best results.

Disassembly (See Fig. 4)

1. Relieve the pressure.

⚠ WARNING

To reduce the risk of serious injury whenever you are instructed to relieve pressure, always follow the **Pressure Relief Procedure** on page 9.

2. With a 7-mm or 9/32-in. socket wrench or Torx® T20 screwdriver, remove the screws (3), air valve cover (5), and valve cover gasket (20).

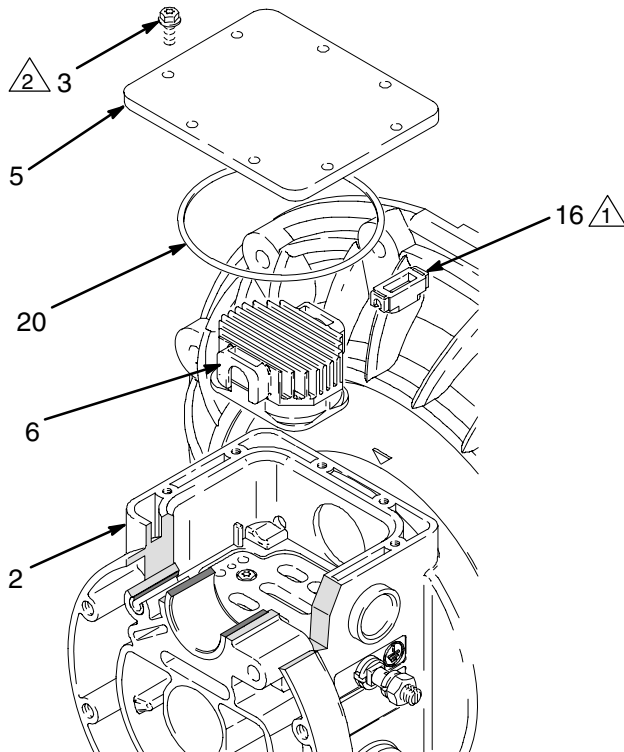

3. Move the main valve (6) to the center position, and pull it out of the cavity. Using a needle-nose pliers, pull the pilot block (16) straight up and out of the cavity.
4. Pull the two actuator pistons (7) out of the bearings (8). Remove the u-cup seals (9) from the pistons. Pull the push pins (18) out of the bearings (17). Remove the o-rings (19) from the housing (2) with an o-ring pick.
5. Inspect the valve plate (11) in place. If damaged, use a Torx® T20 screwdriver or 7-mm or 9/32-in. socket wrench to remove the screws (3).
6. Remove the valve plate (11) and seal (12). See Fig. 5.
7. Inspect the bearings (8 and 17) in place. The bearings are tapered, and, if damaged, must be removed from the outside. See **Removing and Replacing Bearings and Air Gasket** on page 18.
8. Clean all parts and inspect for wear or damage. Replace as needed. Reassemble as explained on page 13.

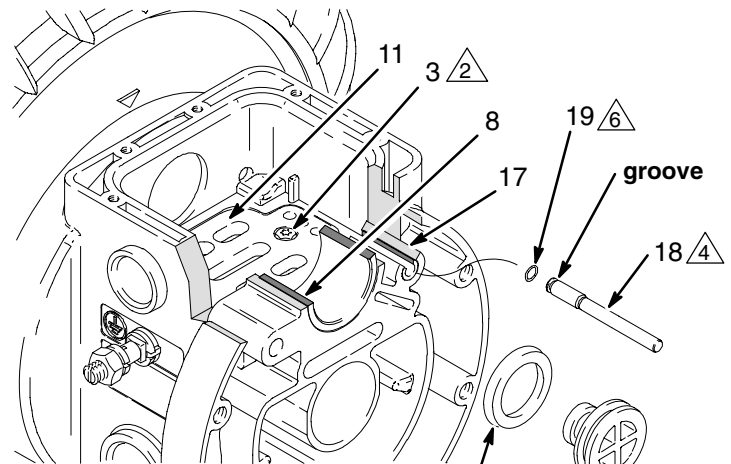

- † 1 Apply grease to lapped surfaces of 16.
- † 2 Torque to 28 to 50 in-lb (3.2 to 5.6 N•m).
- † 3 Install with lips facing narrow end of piston.
- † 4 Insert narrow end first.
- † 5 Insert wide end first.
- † 6 Grease.

06323

Fig. 4

Service

Reassembly

For steps 1 to 3, see Fig. 5.

1. *If you removed the bearings (8 and 17),* install new ones and reassemble the fluid section as explained on page 18.
2. Grease and install the valve plate seal (12) in the groove at the bottom of the valve cavity.
3. Install the valve plate (11) in the cavity with the counter-bore facing up. Insert the screws (3) that hold the valve plate. Using a 7-mm or 9/32-in. socket wrench or Torx® T20 screwdriver, torque the screws to 28 to 50 in-lb (3.2 to 5.6 N•m).

For steps 4 to 11, see Fig. 4.

4. Grease the o-rings (19), and install them in the housing (2). Grease the push pins, and insert them into the bearings (17) narrow end first.
5. Install a u-cup seal (9) on each actuator piston (7), so the lips of the packings face the narrow end of the piston.

6. Grease the u-cup seals (9). Insert the actuator pistons in the bearings (8) wide end first. Leave the narrow end of each piston exposed in the valve cavity.
7. Grease the lower face of the pilot block (16), and install so its tabs snap into the grooves on the ends of the pilot pins (16).
8. Grease the lower face of the main valve (6).
9. Install the main valve (6) so its tabs slip into the grooves on the narrow ends of the actuator pistons (7).
10. Slide the pilot block (16) and the main valve (6) to one side of the valve cavity. See Fig. 4.
11. Align the valve cover o-ring (20) and cover (5) with the holes in the center housing (2). Insert the screws (3). Using a Torx® T20 screwdriver or 7 mm or 9/32-in. socket wrench, torque the screws to 28 to 50 in-lb (3.2 to 5.6 N•m).

 Grease.

 Torque to 28 to 50 in-lb (3.2 to 5.6 N•m).

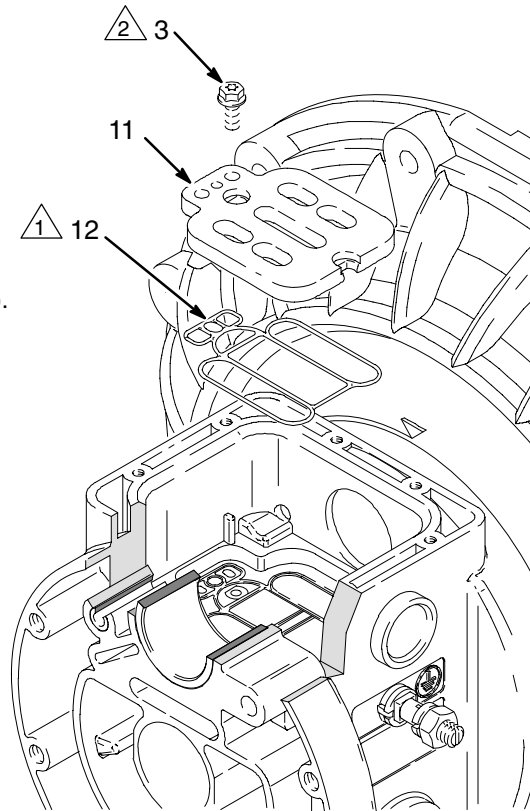

Fig. 5

06324

Service

Ball Check Valve Repair

Tools Required

- Torque wrench
- 15-mm socket wrench
- O-ring pick

NOTE: A Fluid Section Service Kit is available. See the **Repair Kit Matrix** on page 21 to find the correct kit for your pump. Parts included in the kit are marked with an asterisk in the **Parts Drawing** on page 22, for example (201*). Use all the parts in the kit for the best results.

NOTE: To ensure proper seating of the balls (201), always replace the seats (101) when you replace the balls.

Disassembly (See Fig. 6)

1. Relieve the pressure.

⚠ WARNING

To reduce the risk of serious injury whenever you are instructed to relieve pressure, always follow the **Pressure Relief Procedure** on page 9.

⚠ WARNING

Some of the pump parts and assemblies are heavy. Use proper lifting equipment and techniques.

2. Using a 15-mm socket wrench, remove the bolts (54) holding the outlet manifold (50) to the fluid covers (51).
3. Remove the seats (101), balls (201), and o-rings (102) from the fluid covers (51).
4. Remove the inlet manifold bolts (54).
5. Remove the seats (101), balls (201), and o-rings (102) from the fluid covers (51).

Reassembly (See Fig. 6)

1. Clean all parts, and inspect for wear or damage. Replace parts as needed.
2. Reassemble in the reverse order, following all notes in Fig. 6. Be sure all parts are assembled **exactly** as shown.

NOTE: To ensure proper seating, visually check that the manifold (50 or 53) is centered on the fluid covers (51) before you tighten the screws (54).

1. Torque to 55 to 60 ft-lb (75 to 81 N•m). See **Torque Sequence**, page 25.
2. The ball seat is on the same side as the step for the o-ring (102).
3. To ensure proper seating, visually check that the manifold (50 or 53) is centered on the fluid covers (51) before you tighten the screws (54).

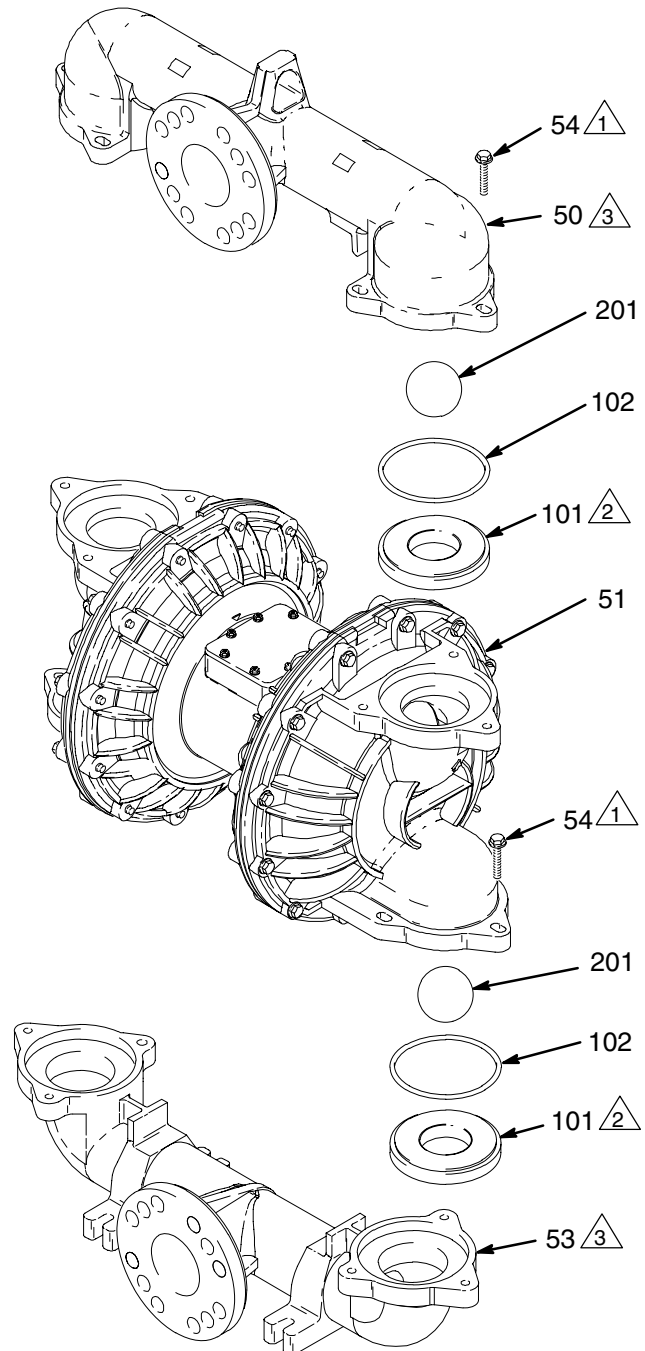

Fig. 6

06325

Service

Diaphragm Repair

Tools Required

- Torque wrench
- 15-mm socket wrench
- 15/16-in. socket wrench
- 7/8 in. open-end wrench
- O-ring pick
- Lithium-base grease, Part No. 111920 (Lubriplate 630AA or equivalent)

NOTE: A Fluid Section Service Kit is available. See the **Repair Kit Matrix** on page 21 to find the correct kit for your pump. Parts included in the kit are marked with an asterisk in the **Parts Drawing** on page 22, for example (201*). Use all the parts in the kit for the best results.

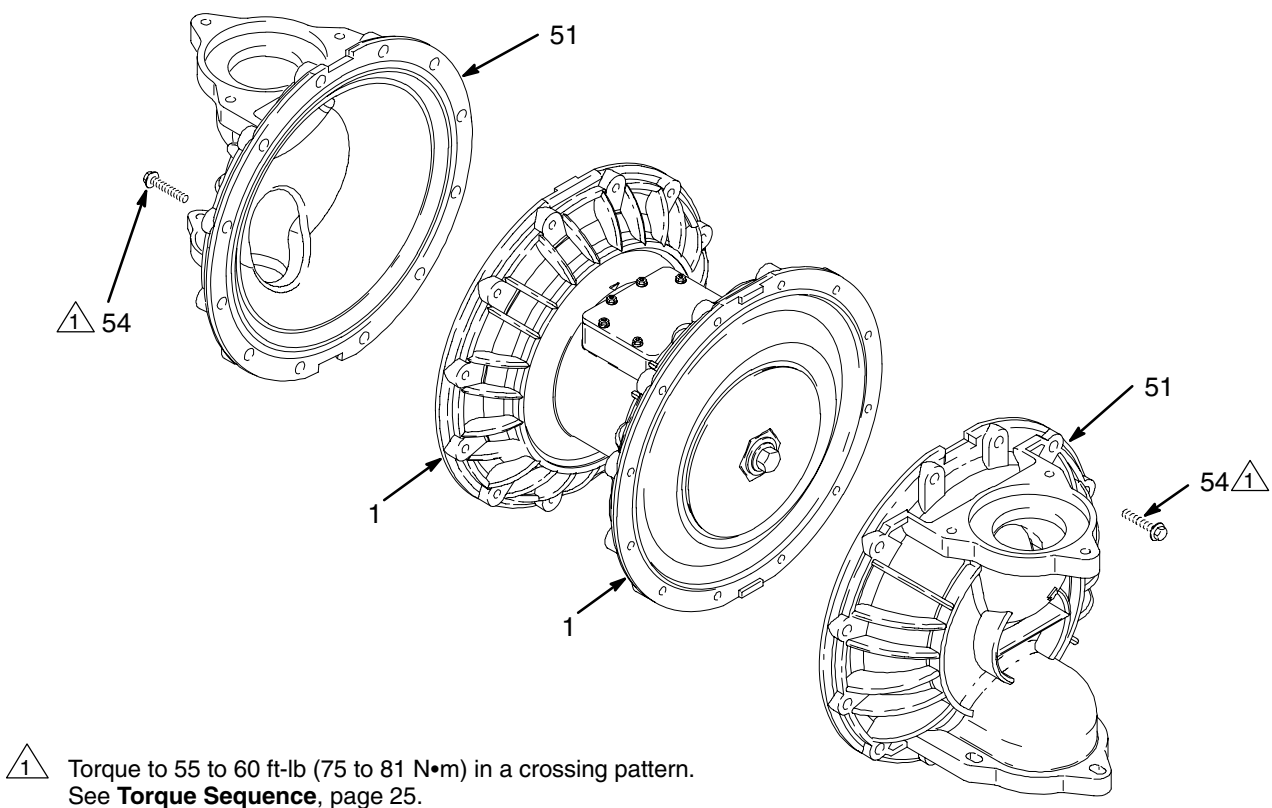

Fig. 7

06326

Service

Disassembly

1. Relieve the pressure.

WARNING

To reduce the risk of serious injury whenever you are instructed to relieve pressure, always follow the **Pressure Relief Procedure** on page 9.

WARNING

Some of the pump parts and assemblies are heavy. Use proper lifting equipment and techniques.

2. Remove the manifolds and disassemble the ball check valves as explained in **Ball Check Valve Repair** on page 14.
3. Using a 15-mm socket wrench, remove the screws (54), and pull the fluid covers off the pump. See Fig. 7.

For steps 4 to 9, see Fig. 8.

4. Using 15/16-in. wrenches or sockets, loosen but do not remove one of the diaphragm plate bolts (62). (whichever one turns)
5. Remove the fluid-side plate (52), diaphragm (301), and air-side plate (57).
For models with PTFE diaphragms, also remove the shim (302) and back-up diaphragm (303).
6. Pull the other diaphragm assembly and the diaphragm shaft (14) out of the center housing (2). Hold the shaft flats with a 7/8-in. wrench, and remove the remaining fluid-side plate (52) from the shaft. Disassemble the remaining diaphragm assembly.
7. Inspect the diaphragm shaft (14) for wear or scratches. If it is damaged, inspect the bearings (13) in place. If the bearings are damaged, see **Removing and Replacing Bearings and Air Gasket** on page 18.
8. Reach into the center housing (2) with an o-ring pick, and hook the u-cup seals (15), then pull them out of the housing. This can be done with the bearings (13) in place.
9. Clean all parts and inspect for wear or damage. Replace parts as needed.

Reassembly (See Fig. 8)

1. Install each u-cup seal (15) so the lips face away from the center of the pump. Lubricate the u-cup seals.
2. Install a diaphragm assembly on one end of the shaft (14) as follows:
 - a. Place a washer (63) and then a white o-ring (64) on the diaphragm bolt (62). The o-ring may fit very snugly on the bolt. Insert the bolt into the fluid-side diaphragm plate (52) as shown in Fig. 8. Grease the bolt threads.
 - b. Lay the diaphragm (301) into the grooves on the fluid-side diaphragm plate (52) so that the side marked AIR SIDE faces the center of the pump.
For models with bolt-through PTFE diaphragms, also install the shim (302) and back-up diaphragm (303), as shown in Fig. 8. Line up diaphragm tabs with tabs on air cover. The bolts must go through the bolt-through PTFE diaphragm.
 - c. Place the air-side diaphragm plate (57) and washer (63) over the bolt. Screw the shaft (14) onto the bolt handtight.
3. Grease the length of the shaft (14), and slide it through the center housing (2).
4. Assemble the other diaphragm assembly to the shaft as explained in step 2.

Step 5 is easiest if the pump is mounted vertically in a vise.

5. Torque the bolts (62) to 100 to 120 ft-lb (136 to 163 N•m).

WARNING

Failure to properly torque the diaphragm bolts (62) could result in a bolt failure. If a diaphragm bolt fails, fluid is exhausted through the muffler. See **Air Exhaust Ventilation** on page 7.

6. Install the fluid cover screws (54) hand tight. Torque the screws to 55 to 60 ft-lb (75 to 81 N•m) in a crossing pattern. See Fig. 7. See **Torque Sequence**, page 25.
7. Reassemble the ball check valves and manifolds as explained on page 14.

Service

Cutaway View with Diaphragms in Place

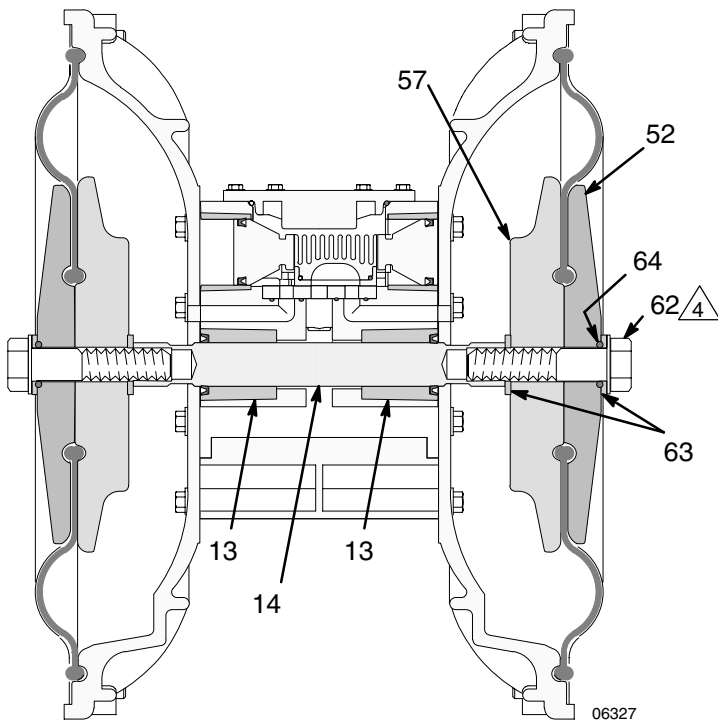

Cutaway View with Diaphragms Removed

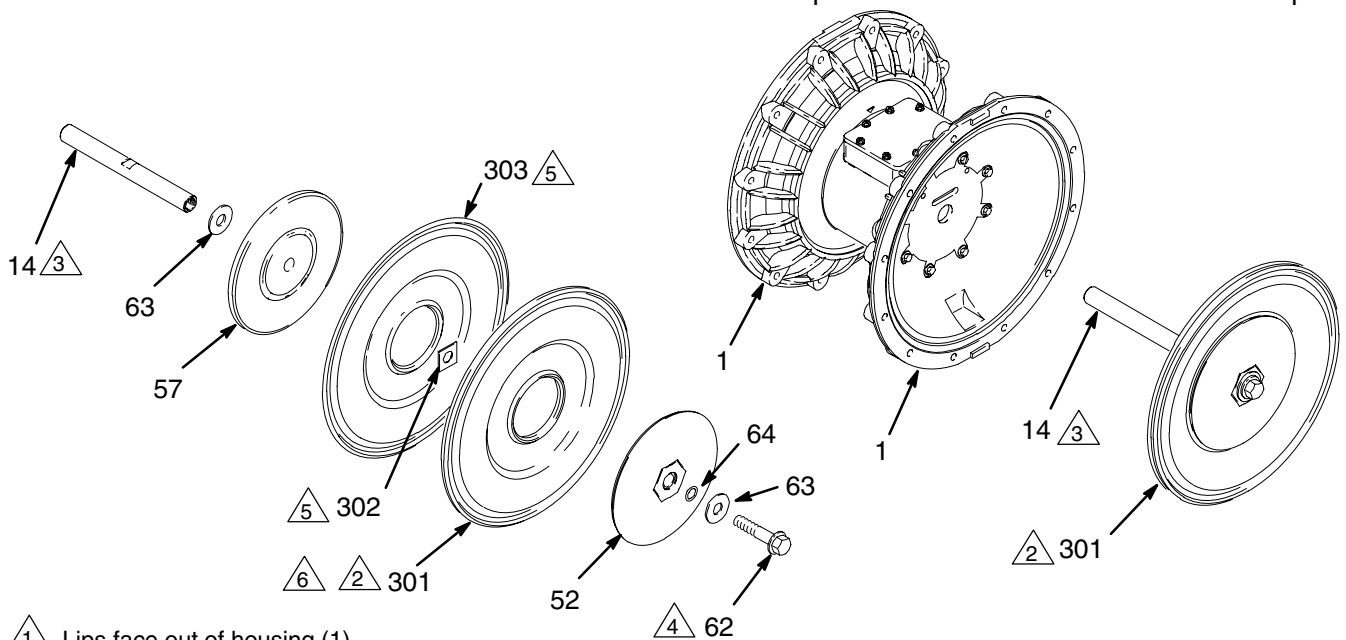
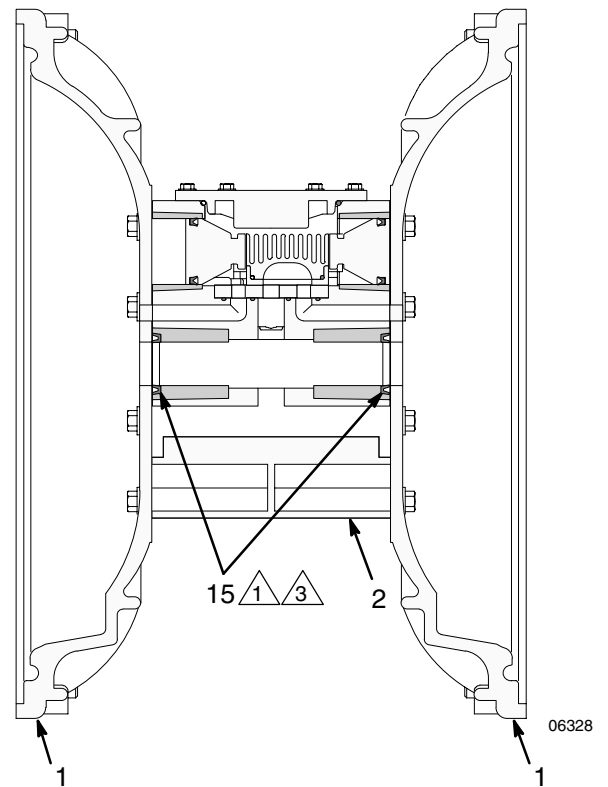

- ① Lips face out of housing (1).
- ② Side marked AIR SIDE must face center housing (2).
- ③ Grease.
- ④ Torque to 100 to 120 ft-lb (136 to 163 N•m).
- ⑤ Used only in models with PTFE diaphragms.
- ⑥ Bolt-through PTFE diaphragms: Line up diaphragm tabs with tabs on air cover. Bolts go through the diaphragm.

06329A

Fig. 8

Service

Removing and Replacing Bearings and Air Gasket (See Fig. 9)

Tools Required

- Torque wrench
- 13-mm socket wrench
- Bearing puller
- O-ring pick
- Press, or block and mallet

Disassembly

NOTE: Do not remove undamaged bearings. This procedure is only for replacing bearings that are damaged.

1. **Relieve the pressure.**

WARNING

To reduce the risk of serious injury whenever you are instructed to relieve pressure, always follow the **Pressure Relief Procedure** on page 9.

2. Remove the manifolds, and disassemble the ball check valves as explained on page 14.
 3. Remove the fluid covers and diaphragm assemblies as explained on pages 15 and 16.
- NOTE:** If you are removing only the diaphragm shaft bearing (8), skip step 4.
4. Disassemble the air valve as explained on page 12.
 5. Using a 13-mm socket wrench, remove the screws (27) holding the air covers (1) to the center housing (2). See Fig. 9.

6. Remove the air cover gaskets (10). Always replace the gaskets with new ones.
7. Use a bearing puller to remove the diaphragm shaft bearings (13), piston actuator bearings (8), and push pin bearings (17). Do not remove any bearings if they are not damaged.

Reassembly

1. Insert the bearings (8, 13, and 17) into the housing (2), **tapered end first**. Using a press or a block and mallet, press-fit each bearing so it is flush with the surface of the housing.
2. Reassemble the air valve as explained on page 13.
3. Install the u-cup shaft seals (15) with the lips facing away from the bearing (13). See Fig. 8.
4. Align each new air cover gasket (10) so the push pin (18) protruding from the center housing (2) fits through the proper hole (H) in the gasket, as shown in Fig. 8.
5. Align each air cover (1) so the through hole is on the bottom, as shown in Fig. 8. Install the screws (27) handtight. Using a 13-mm socket, torque the screws oppositely and evenly to 19 to 21 ft-lb (26 to 28 N•m).
6. Install the diaphragm assemblies and fluid covers as explained on page 16.
7. Reassemble the ball check valves and manifolds as explained on page 14.

Service

Detail of Bearings

- 1 Press-fit bearings flush with surface of center housing (2).
- 2 Torque to 19 to 21 ft-lb (26 to 28 N•m).

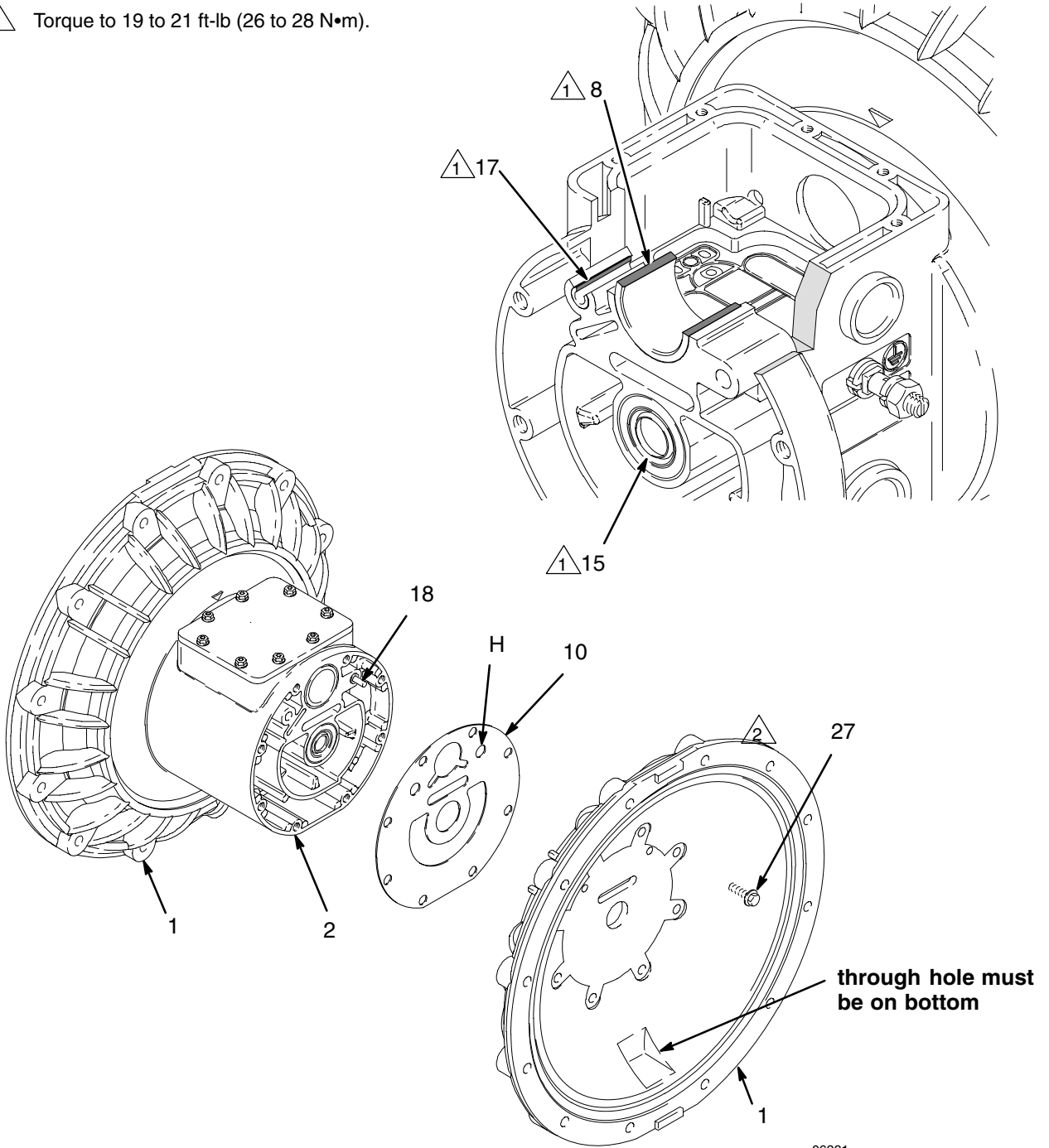

06330

06331

Fig. 9

Pump Matrix

Husky 3275 Pumps, Series C

Your Model No. is marked on the pump's serial plate. To determine the Model No. of your pump from the following matrix, select the six digits that describe your pump, working from left to right. The first digit is always **D**, designating Husky diaphragm pumps. The remaining five digits define the materials of construction.

For example, a pump with an aluminum air motor and fluid section, TPE seats, PTFE balls, and TPE diaphragms is Model **D K 3 5 1 5**. To order replacement parts, refer to the **Part Lists** on pages 23 and 24. *The digits in the matrix **do not** correspond to the reference numbers in the **Parts Drawing** and **Parts Lists**.*

Diaphragm Pump	Air Motor	Fluid Section	–	Seats	Balls	Diaphragms
232505*	aluminum	aluminum	–	TPE	acetal	TPE
D (for all pumps)	K (aluminum)	3 (aluminum)	–	0 (null)	0 (null)	0 (null)
			–	3 (316 SST)	1 (PTFE)	
			–	5 (TPE)	2 (acetal)	5 (TPE)
			–	6 (Santoprene®)	6 (Santoprene®)	6 (Santoprene®)
			–	G (Geolast®)	G (Geolast®)	G (Geolast®)
						P (bolt-through PTFE)

* 232505, Aluminum 3275 Pump, Series C

Model No. 232505 is a private-label aluminum 3275 pump. Other than the label, it is the same as Model No. DK3525.

* 24D619, Aluminum 3275 Pump, Series A

Model No. 24D619 is a private-label aluminum 3275 pump. Other than the label and the parts listed below, it is the same as Model No. DK3525.

Ref. No. 54 is Part No. 16D109 SCREW, M12 x 1.75 x 55 mm (2.17"); stainless steel. Qty: 40

Repair Kit Matrix

For Husky 3275 Pumps, Series C

Repair kits may be ordered separately. To repair the air valve, order the Air Valve Service Kit, **Part No. 238765** (see page 23). Parts included in the Air Valve Service Kit are marked with a symbol in the **Air Motor Parts List**, for example (3†).

To repair the seats, balls, and diaphragms, select the six digits that describe your pump from the following matrix, working from left to right. The first digit is always **D**, the second digit is always **0** (zero), and the third digit is always **K**. The remaining three digits define the materials of construction. Parts included in the kit are marked with an asterisk in the **Parts Drawing** on page 22, for example (201*).

For example, if your pump has Santoprene® seats, PTFE balls, and Santoprene® diaphragms, you need to order Repair Kit **D 0 K 6 1 6**. *The digits in the matrix do not correspond to the reference numbers in the **Parts Drawing** and **Parts Lists** on pages 23 and 24.*

Diaphragm Pump	Air Motor	Shaft O-Ring	–	Seats	Balls	Diaphragms
D (for all pumps)	0 (for all pumps)	K (for all pumps)	–	0 (null)	0 (null)	0 (null)
			–	3 (316 SST)	1 (PTFE)	
			–	5 (TPE)	2 (acetal)	5 (TPE)
			–	6 (Santoprene®)	6 (Santoprene®)	6 (Santoprene®)
			–	G (Geolast®)	G (Geolast®)	G (Geolast®)
						P (bolt-through PTFE)

Parts Drawing

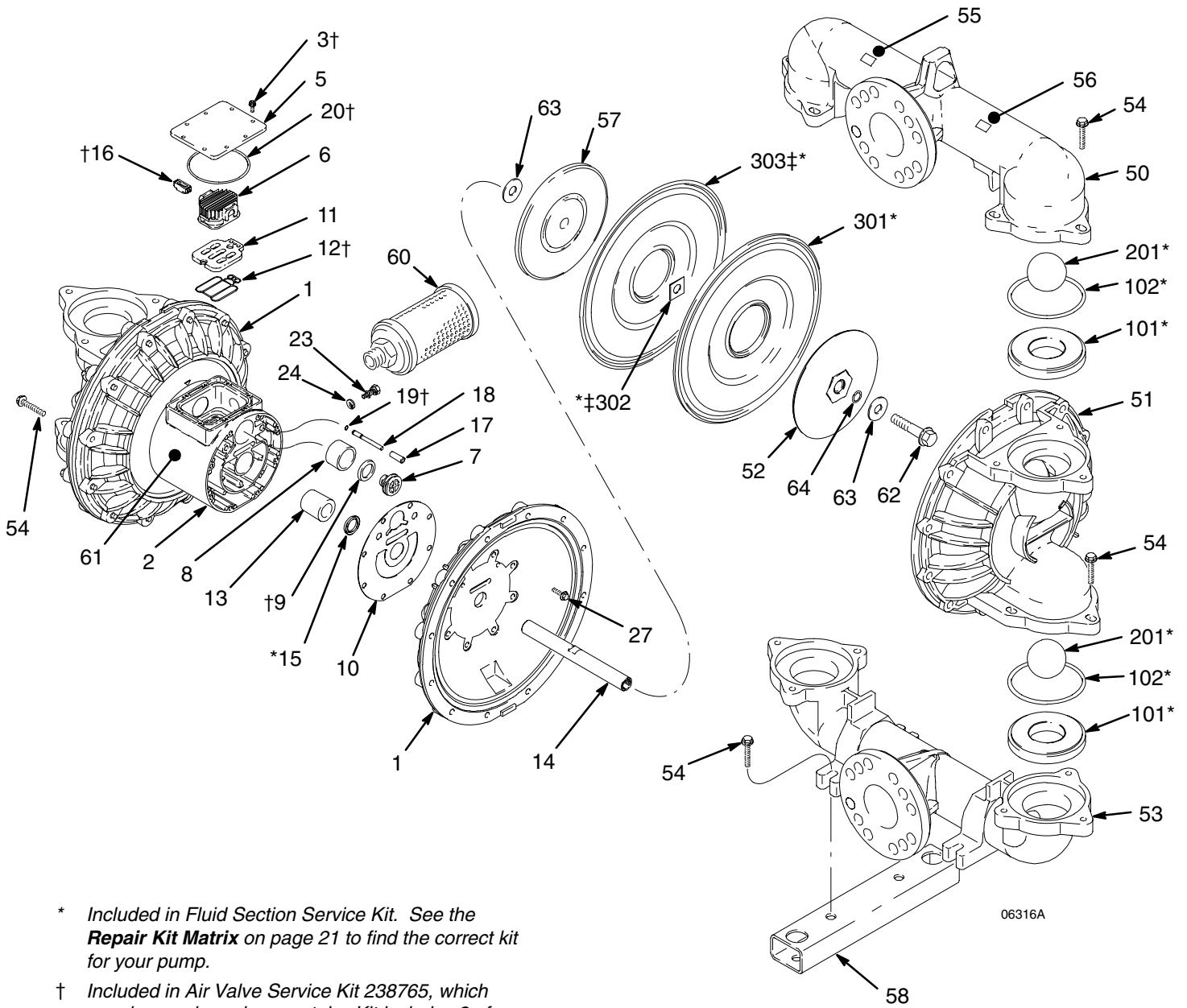

* Included in Fluid Section Service Kit. See the **Repair Kit Matrix** on page 21 to find the correct kit for your pump.

† Included in Air Valve Service Kit 238765, which may be purchased separately. Kit includes 2 of 113554.

‡ Used only in models with PTFE diaphragms.

Parts Lists

Air Motor Parts List (Matrix Column 2)

Digit	Ref. No.	Part No.	Description	Qty.
K	1	190827	COVER, air; aluminum	2
	2	190826	HOUSING, center; aluminum	1
	3†	113554	SCREW, mach, Torx®, hex flange hd; M5 x 0.8 x 16 mm (0.63"); SST	10
	5	190831	COVER, valve; aluminum	1
	6	240222	MAIN VALVE; aluminum	1
	7	190822	PISTON, actuator; acetal	2
	8	190823	BEARING, piston; acetal	2
	9†	113249	SEAL, u-cup; nitroxile nitrile	2
	10	190835	GASKET, air cover; HDPE foam	2
	11	190817	PLATE, valve; SST	1
	12†	190825	SEAL, valve plate; Buna-N	1
	13	190819	BEARING, shaft; acetal	2
	14	190818	SHAFT; SST	1
	16†	188614	BLOCK, pilot; acetal	1
	17	190821	BEARING, pin; acetal	2
	18	190820	PIN, push; SST	2
	19†	114375	PACKING, o-ring; nitrile	2
	20†	113252	PACKING, o-ring; Buna-N	1
	23	104029	CLAMP, grounding	1
	24	104582	WASHER, tab	1
27	114193	SCREW, mach, hex, washer head	16	

† Included in Air Valve Service Kit 238765, which may be purchased separately. Kit includes 2 of 113554.

* Included in Fluid Section Service Kit. See the **Repair Kit Matrix** on page 21 to find the correct kit for your pump.

Fluid Section Parts List (Matrix Column 3)

Digit	Ref. No.	Part No.	Description	Qty.
3	50	190830	MANIFOLD, outlet; aluminum	1
	51	190828	COVER, fluid; aluminum	2
	52	191990	PLATE, fluid side; aluminum	2
	53	190829	MANIFOLD, inlet; aluminum	1
	54	113629	SCREW, M12 x 1.75 x 55 mm (2.17"); aluminum	40
	55▲	290267	LABEL, warning	1
	56▲	290266	LABEL, warning	1
	57	192196	PLATE, air side; aluminum	2
	58	190906	FOOT, mounting; carbon steel	2
	60	111897	MUFFLER	1
	61	290211	LABEL, identification	1
	62	114313	SCREW, hex washer head; 5/8-11 x 3	2
	63	114314	WASHER, plain; 5/8"	4
	64	114315	PACKING, o-ring; PTFE	2

▲ Replacement Danger and Warning labels, tags, and cards are available at no cost.

Parts Lists

Seat Parts List (Matrix Column 4)

Digit	Ref. No.	Part No.	Description	Qty.
3	101*	190840	SEAT; 316 SST	4
	102*	113449	O-RING; PTFE	4
5	101*	190837	SEAT; TPE	4
	102*	113449	O-RING; PTFE	4
6	101*	190836	SEAT; Santoprene®	4
	102*	113449	O-RING; PTFE	4
G	101*	194217	SEAT; Geolast®	4
	102*	113449	O-RING; PTFE	4

Diaphragm Parts List (Matrix Column 6)

Digit	Ref. No.	Part No.	Description	Qty.
5	301*	190839	DIAPHRAGM; TPE	2
	15*	113265	SEAL, u-cup; nitroxile nitrile	2
6	301*	190838	DIAPHRAGM; Santoprene®	2
	15*	113265	SEAL, u-cup; nitroxile nitrile	2
G	301*	194218	DIAPHRAGM; Geolast®	2
	15*	113265	SEAL, u-cup; nitroxile nitrile	2
P	301*	15M510	BOLT-THROUGH DIAPHRAGM; PTFE	2
	302*	193414	SHIM	2
	303*	190838	DIAPHRAGM, back-up; Santoprene®	2
	15*	113265	SEAL, u-cup; nitroxile nitrile	2

Ball Parts List (Matrix Column 5)

Digit	Ref. No.	Part No.	Description	Qty.
1	201*	113253	BALL; PTFE	4
2	201*	113266	BALL; acetal	4
6	201*	113254	BALL; Santoprene®	4
G	201*	114754	BALL; Geolast®	4

* Included in Fluid Section Service Kit. See the **Repair Kit Matrix** on page 21 to find the correct kit for your pump.

Technical Data

Maximum fluid working pressure 120 psi
(0.8 MPa, 8 bar)
Air operating range 20 to 120 psi
(0.14 to 0.8 MPa, 1.4 to 8 bar)
Maximum air consumption 325 scfm
Air consumption at 70 psi and 100 gpm
(480 kPa, 4.8 bar and 379 lpm) 120 scfm
(1.26 m³/min)
Maximum free-flow delivery 275 gpm (1,041 lpm)
Maximum pump speed 135 cpm
Gallons (liters) per cycle 2.0 (7.6)
Maximum suction lift (water)
Dry 8 ft (2.5 m)
Wet 28 ft (8.5 m)
Maximum size pumpable solids 3/8 in. (9.4 mm)

* Sound power level at 120 psi (0.8 MPa, 8 bar)
and 105 cpm 101 dBA
* Sound pressure level at 120 psi (0.8 MPa, 8 bar)
and 105 cpm 86 dBA
* Sound pressure level at 50 psi (0.3 MPa, 3 bar)
and 50 cpm 76 dBA
Air inlet 3/4 npt(f)
Maximum operating temperature 150° F (65° C)
Fluid inlet 3-in. ANSI 4-bolt / DIN 8-bolt flange
Fluid outlet 3-in. ANSI 4-bolt / DIN 8-bolt flange
Wetted parts aluminum, PTFE, Geolast®
Santoprene®, TPE, plated steel, acetal, SST
Weight approximately 150 lb (68 kg)

* Sound power level measured per ISO Standard 9614-2. Sound pressure measured 1 meter from pump.

Geolast® and Santoprene® are registered trademarks of the Monsanto Company.

Torx® is a registered trademark of Camcar, Division of Textron, Inc.

Torque Sequence

Always follow torque sequence when instructed to torque fasteners.

1. Left/Right Fluid Cover

Torque bolts to 55–60 ft–lb (75–81 N•m)

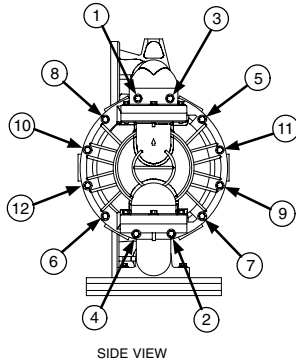

3. Outlet Manifold

Torque bolts to 55–60 ft–lb (75–81 N•m)

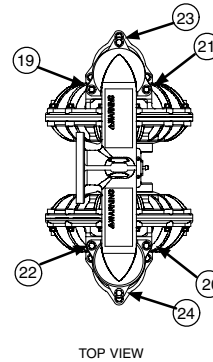

2. Inlet Manifold

Torque bolts to 55–60 ft–lb (75–81 N•m)

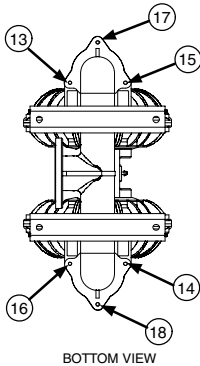

Dimensional Drawings

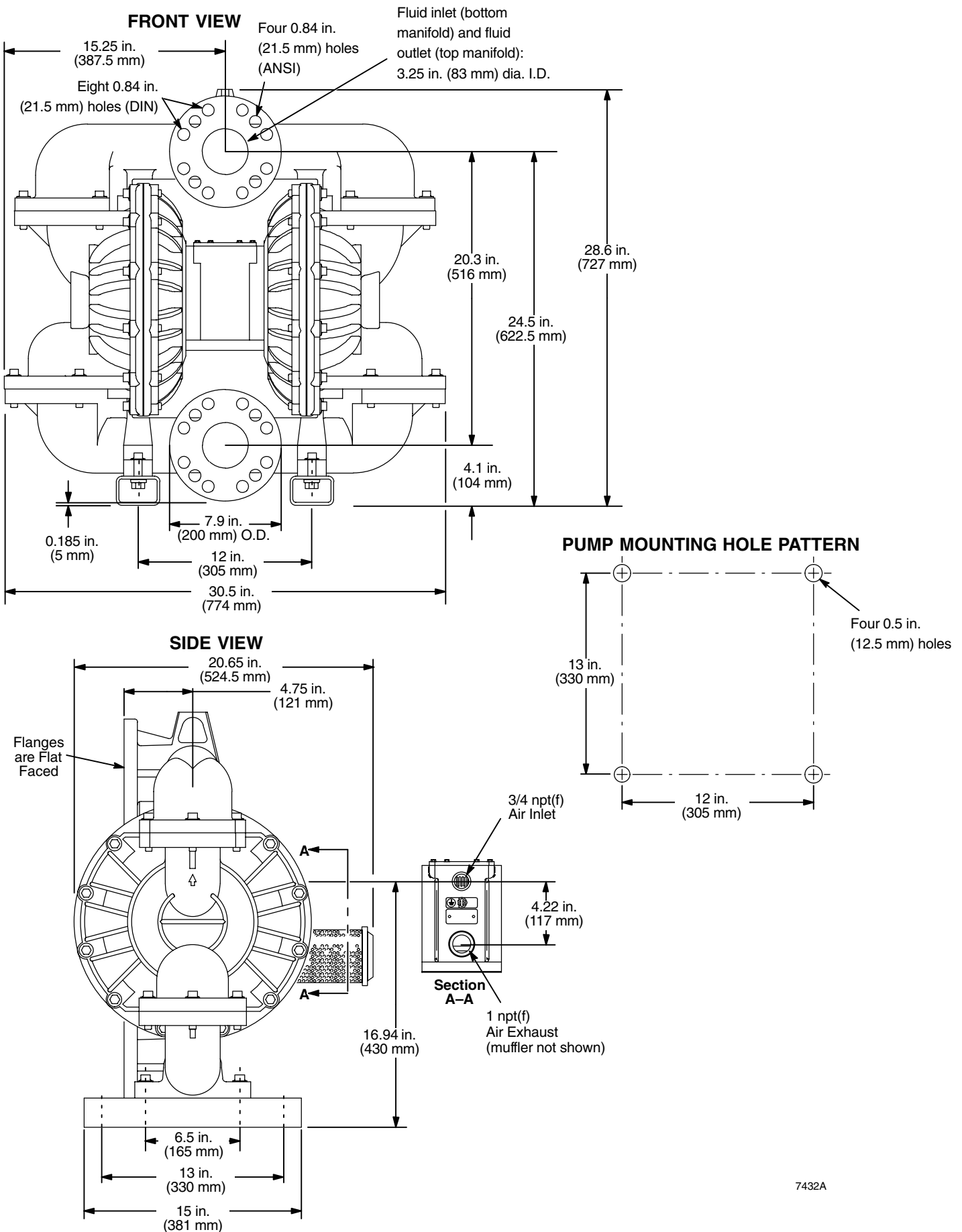

7432A

Performance Charts

Aluminum Husky 3275 Fluid Outlet Pressure

Test Conditions: Pump tested in water with inlet submerged.

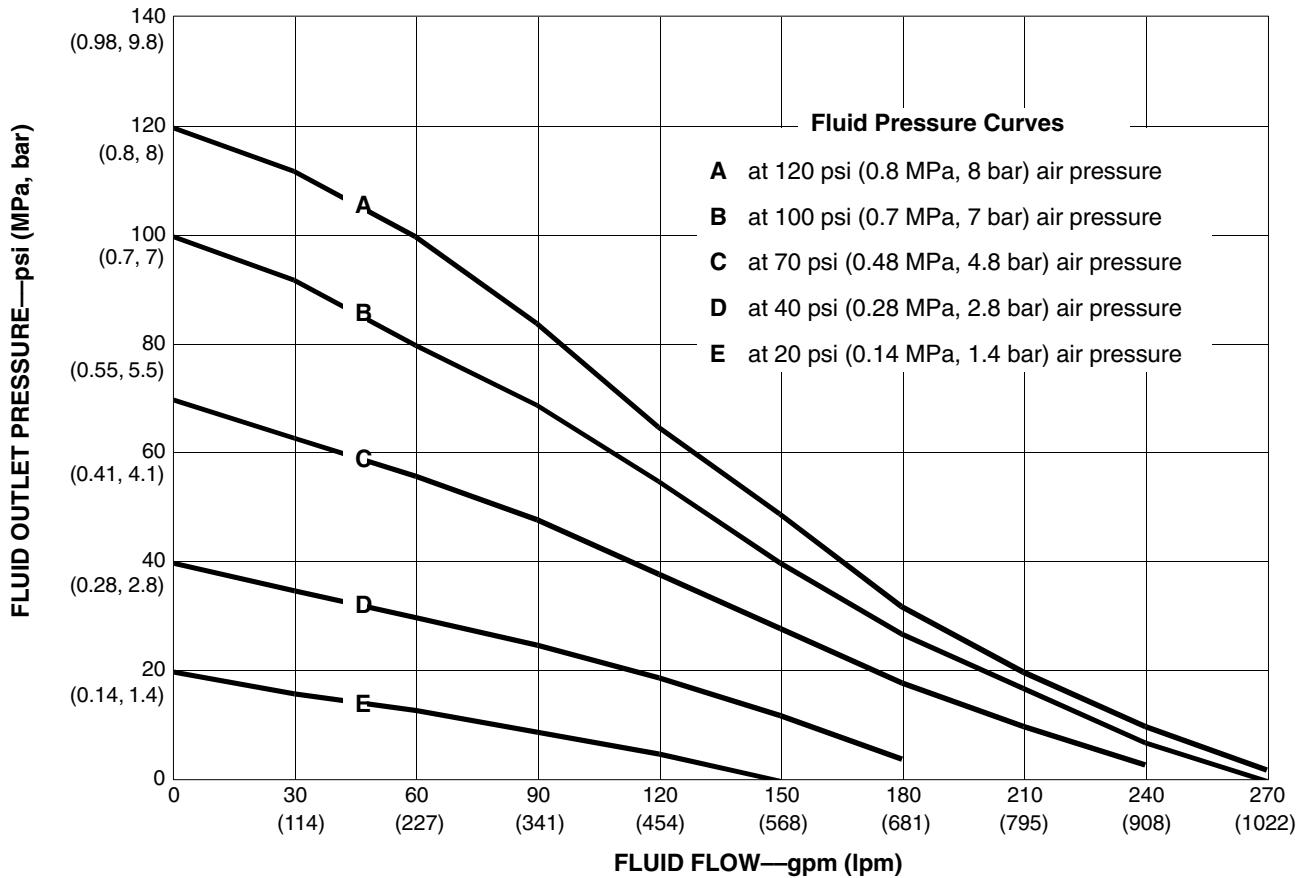

To find Fluid Outlet Pressure (psi/MPa/bar) at a specific fluid flow (gpm/lpm) and operating air pressure (psi/MPa/bar):

1. Locate fluid flow rate along bottom of chart.
2. Follow vertical line up to intersection with selected fluid outlet pressure curve.
3. Follow left to scale to read fluid outlet pressure.

To calculate Pressure Head in feet at a specific fluid outlet pressure (psi):

$$\text{pressure head, feet} = (\text{psi} * 2.31) / \text{specific gravity of fluid}$$

To calculate Pressure Head in meters at a specific fluid outlet pressure (MPa):

$$\text{pressure head, meters} = (\text{MPa} * 102) / \text{specific gravity of fluid}$$

To calculate Pressure Head in meters at a specific fluid outlet pressure (bar):

$$\text{pressure head, meters} = (\text{bar} * 10.2) / \text{specific gravity of fluid}$$

Performance Charts

Aluminum Husky 3275 Air Consumption

Test Conditions: Pump tested in water with inlet submerged.

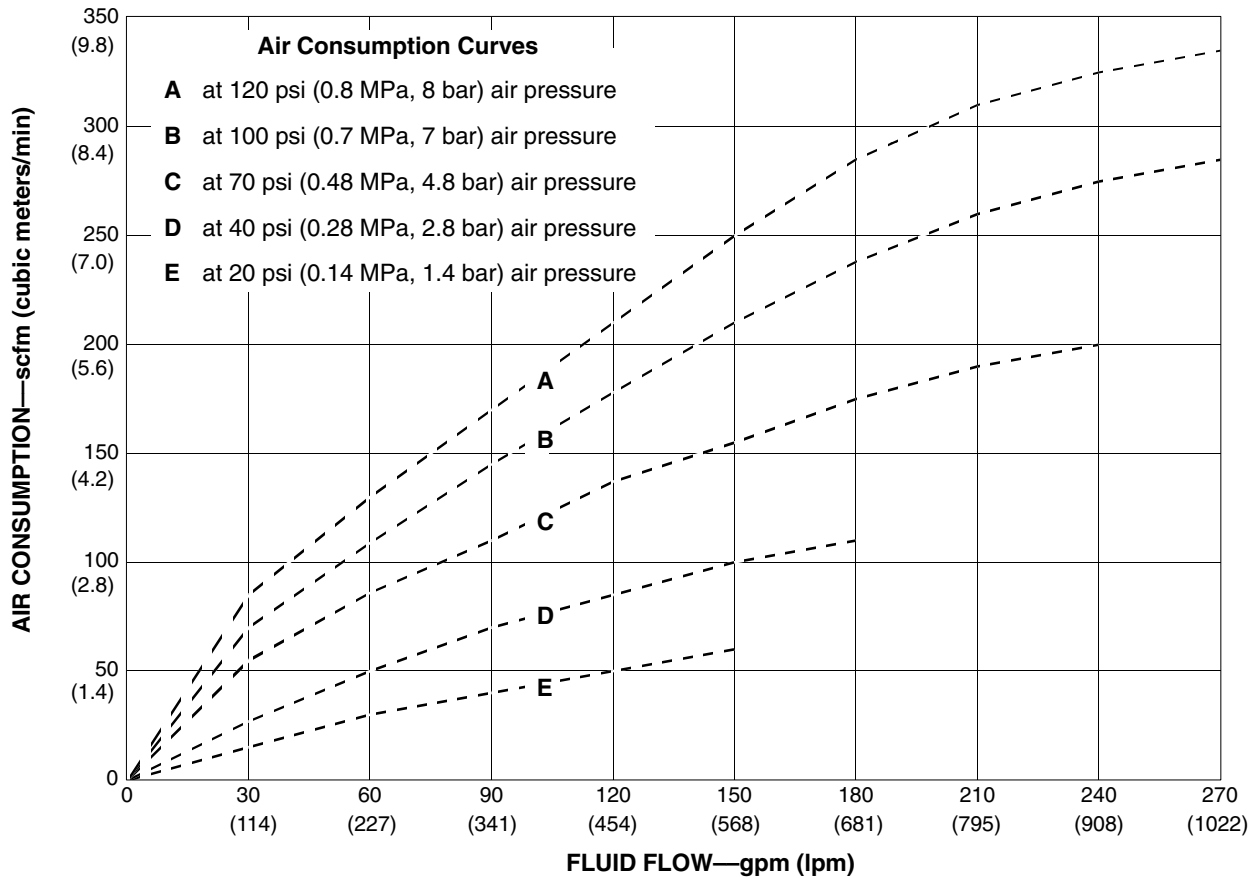

To find Pump Air Consumption (scfm or m^3/min) at a specific fluid flow (gpm/lpm) and air pressure (psi/MPa/bar):

1. Locate fluid flow rate along bottom of chart.
2. Read vertical line up to intersection with selected air consumption curve.
3. Follow left to scale to read air consumption.

Graco Warranties

Graco Standard Husky Pump Warranty

Graco warrants all equipment manufactured by Graco and bearing its name to be free from defects in material and workmanship on the date of sale to the original purchaser for use. With the exception of any special, extended, or limited warranty published by Graco, Graco will, for a period of five years from the date of sale, repair or replace any part of the equipment determined by Graco to be defective. This warranty applies only when the equipment is installed, operated and maintained in accordance with Graco's written recommendations.

This warranty does not cover, and Graco shall not be liable for general wear and tear, or any malfunction, damage or wear caused by faulty installation, misapplication, abrasion, corrosion, inadequate or improper maintenance, negligence, accident, tampering, or substitution of non-Graco component parts. Nor shall Graco be liable for malfunction, damage or wear caused by the incompatibility of Graco equipment with structures, accessories, equipment or materials not supplied by Graco, or the improper design, manufacture, installation, operation or maintenance of structures, accessories, equipment or materials not supplied by Graco.

This warranty is conditioned upon the prepaid return of the equipment claimed to be defective to an authorized Graco distributor for verification of the claimed defect. If the claimed defect is verified, Graco will repair or replace free of charge any defective parts. The equipment will be returned to the original purchaser transportation prepaid. If inspection of the equipment does not disclose any defect in material or workmanship, repairs will be made at a reasonable charge, which charges may include the costs of parts, labor, and transportation.

THIS WARRANTY IS EXCLUSIVE, AND IS IN LIEU OF ANY OTHER WARRANTIES, EXPRESS OR IMPLIED, INCLUDING BUT NOT LIMITED TO WARRANTY OF MERCHANTABILITY OR WARRANTY OF FITNESS FOR A PARTICULAR PURPOSE.

Graco's sole obligation and buyer's sole remedy for any breach of warranty shall be as set forth above. The buyer agrees that no other remedy (including, but not limited to, incidental or consequential damages for lost profits, lost sales, injury to person or property, or any other incidental or consequential loss) shall be available. Any action for breach of warranty must be brought within six years of the date of sale.

Graco makes no warranty, and disclaims all implied warranties of merchantability and fitness for a particular purpose in connection with accessories, equipment, materials or components sold but not manufactured by Graco. These items sold, but not manufactured by Graco (such as electric motors, switches, hose, etc.), are subject to the warranty, if any, of their manufacturer. Graco will provide purchaser with reasonable assistance in making any claim for breach of these warranties.

In no event will Graco be liable for indirect, incidental, special or consequential damages resulting from Graco supplying equipment hereunder, or the furnishing, performance, or use of any products or other goods sold hereto, whether due to a breach of contract, breach of warranty, the negligence of Graco, or otherwise.

FOR GRACO CANADA CUSTOMERS

The parties acknowledge that they have required that the present document, as well as all documents, notices and legal proceedings entered into, given or instituted pursuant hereto or relating directly or indirectly hereto, be drawn up in English. Les parties reconnaissent avoir convenu que la rédaction du présente document sera en Anglais, ainsi que tous documents, avis et procédures judiciaires exécutés, donnés ou intentés à la suite de ou en rapport, directement ou indirectement, avec les procédures concernées.

Extended Product Warranty

Graco warrants all Husky 205, 307, 515, 716, 1040, 1590, 2150, and 3275 air valve center sections to be free from defects in material and workmanship for a period of fifteen years from date installed in service by the original purchaser. Normal wear of items such as packings or seals are not considered to be defects in material and workmanship.

Five years	Graco will provide parts and labor.
Six to Fifteen years	Graco will replace defective parts only.

Graco Information

For the latest information about Graco products, visit www.graco.com.

TO PLACE AN ORDER, contact your Graco distributor, or call one of the following numbers to identify the distributor closest to you:

1-800-367-4023 Toll Free, 612-623-6921, 612-378-3505 Fax

All written and visual data contained in this document reflects the latest product information available at the time of publication.

Graco reserves the right to make changes at any time without notice.

Original instructions. This manual contains English. MM 308639

Graco Headquarters: Minneapolis

International Offices: Belgium, Korea, China, Japan

GRACO INC. P.O. BOX 1441 MINNEAPOLIS, MN 55440-1441

Copyright 2002, Graco Inc. is registered to ISO 9001

www.graco.com

Revised 03/2010